

Underground **Machine Parts**



Bend-tech.
ENGINEERED TO DRIVE EFFICIENCY



Table of Contents

UNDERGROUND REPLACEMENT PARTS	3
CAT 1700 LOADER.....	4
CAT 2900 LOADER.....	8
CAT 3000 LOADER.....	12
CAT AD30 TRUCK.....	14
CAT AD45 TRUCK.....	16
CAT AD55-DNW TRUCK.....	18
CAT AD55B-JNW TRUCK.....	20
CAT AD60-KNW TRUCK.....	22
EPIROC/ATLAS MT42 TRUCK.....	24
EPIROC/ATLAS MT54 TRUCK.....	26
EPIROC/ATLAS MT65 TRUCK.....	28

EPIROC/ATLAS MT65 TRUCK - 2017 BEYOND.....	30
EPIROC/ATLAS MT2010 TRUCK.....	32
EPIROC/ATLAS MT5020 TRUCK.....	34
EPIROC/ATLAS MT6020 TIER 2 TRUCK.....	36
SANDVIK LH514 LOADER	38
SANDVIK LH517 LOADER	40
SANDVIK LH621 LOADER	42
SANDVIK LH621 LOADER - HYDRAULIC	44
SANDVIK TH663 / TH551 TRUCK.....	46
SANDVIK DD421 DRILL	50
BEND-TECH HANDRAIL SYSTEMS	52
MAINTENANCE PLATFORMS.....	54
ALLTUFF STANDS	56
WORKSHOP TRESTLES.....	57
GENERAL PURPOSE STEEL RACK.....	58
WHITEBOARD BENCHES.....	58
CDEC PROCESS.....	59

“ Making maintenance on-site safe, efficient and easy ”

Underground Replacement Parts

Bend-tech replacement parts are designed to suit specific underground machines. Our products are engineered to improve the safety and efficiency of underground operations and working at heights scenarios.

Safety

Our handrails are easily engaged and folded to ensure operators can maintain the critical 3-points of contact at all times. Kick plates incorporated into most handrails to minimise drop hazards from the deck. Our replacement parts have been designed with the safety of the operators and those in the surrounding work areas at the forefront.

Engineered Tough

All of our underground machinery replacement parts have been designed and engineered to comply with the relevant Australian Standard.

Environmentally Resistant

A heavy-duty zinc coating provides our parts with corrosion protection, followed by a safety yellow topcoat or machine specific colours.

Unrivalled Economy

Our low-folding handrails prevent damage, which reduces the chance of needing replacement. We are able to deliver our high performance, high quality replacement parts at a significant saving when compared to OEM parts.

Improved Hinge Design

Our field studies have yielded a hinge system that far exceeds the performance of the OEM hinge system. Constructed out of stainless steel to ensure corrosion resistance and improved functionality, our hinge system allows operators to easily engage and fold our handrails.

IMPROVED HINGE

Patent Pending and Registered Design



CAT1700 Loader

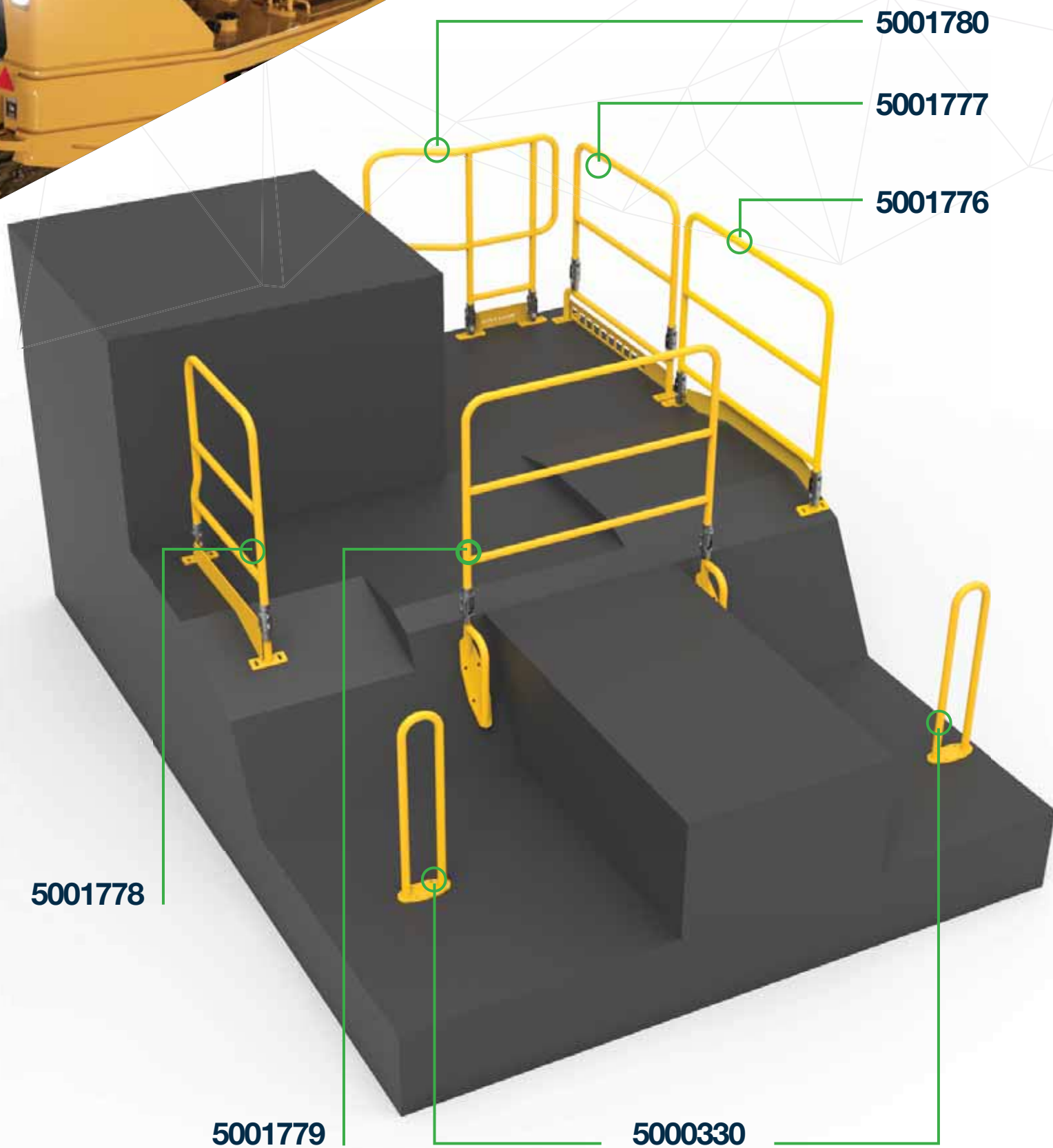

5001780

5001777

5001776

5001778

5001779

5000330

CAT1700 Loader



HANDRAIL 5001776
OEM No. 453-8708 (OLD 318-7892)



HANDRAIL 5001777
OEM No. 453-8707 (OLD 318-7901)



HANDRAIL 5001778
OEM No. 453-8698 (OLD 318-7896)



HANDRAIL 5001779
OEM No. 453-8709 feet attached (OLD 318-7885)



HANDRAIL 5001780
OEM No. 453-8706 (OLD 318-7853)



*** HANDRAIL 5000330**
OEM No. 230-9812



*** TILT CYLINDER GUARD 5001946**
OEM No. 199-5816

FULL HANDRAIL SET TO SUIT CAT LOADER 1700 - PART NO: 5001781



*** NOT INCLUDED IN FULL SET**

CAT1700 Loader



CAT1700 Door

To suit Caterpillar 1700 JLK Machines
OEM No.291-0662

* **Part No. 5001817**

Benefits include:

- Heavy duty construction
- Significant savings which takes away the need for downtime while repairing damaged doors
- Can be supplied with seals and glass
- Precision manufactured for fast fit up to your machine



CAT1700 Folding Guards

Made to suit CAT 1700 Loaders, our fender acts as a wheel guard and is designed to withstand the harshest underground mining environments.

Benefits include:

- Heavy duty hinged folding system
- Double pin design to eliminate sagging
- No need to take off the fender when servicing behind the wheel guard
- Stainless pins with greasing points
- Patent pending



CAT1700 Dog Bone

Bend-tech's Dog Bone components are precision manufactured and machined from high tensile steel, with hardened and ground bushes. To suit OEM No.186-9866

* **Part No. 5001955**

Benefits include:

- Constructed in one piece to increase strength
- Grease channels underneath to prevent rock damage
- Grease channel machined into the dogbone body
- Patent pending

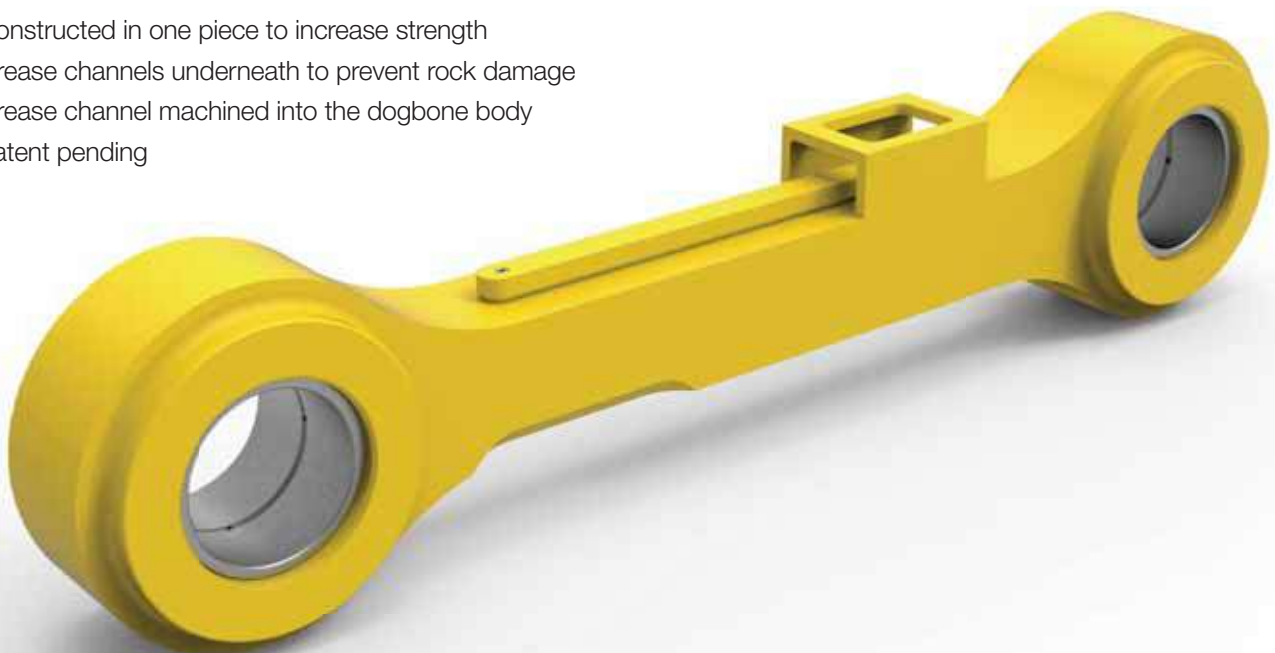

* **NOT INCLUDED IN FULL SET**

CAT2900 Loader

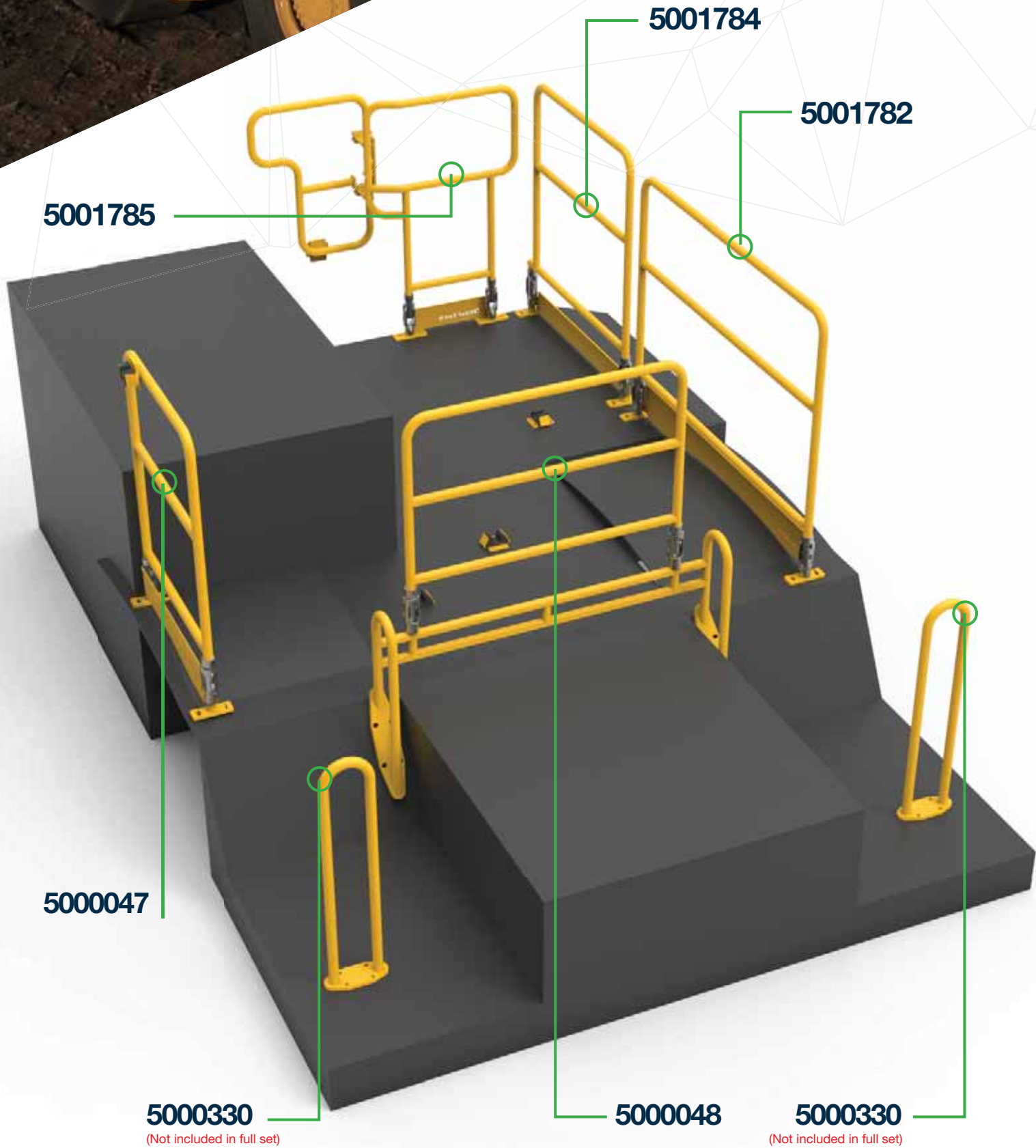

CAT2900 Loader



HANDRAIL 5001782

OEM No. 453-8703 (OLD 321-4739)



HANDRAIL 5000047

OEM No. 453-8705 (OLD 321-4745)



HANDRAIL 5000048

OEM No. 452-8704 feet attached (OLD 321-4753)



HANDRAIL 5001784

OEM No. 453-8702 (OLD 321-4758)



HANDRAIL 5001785

OEM No. 453-8701 (OLD 321-4767)



*** HANDRAIL 5000330**

OEM No. 230-9812



*** CAB HANDRAIL 5001816**

OEM No. 250-0931



*** HANDRAIL**

CAMERA OPTION 5000048M



*** COVER - LUBRICATION LINES 5000333**

OEM No. 203-1563



*** CYLINDER GUARD 5001789**

OEM No. Cylinder Guard - 217-0347



*** REAR GUARD RH 5000334**

OEM No. 252-5933



*** WINDOW GUARD 5000331**

OEM No. 251-7851



*** FENDER 5001787**

OEM No. AS-RH 230-9241



*** FENDER 5001788**

OEM No. AS-LH 230-9240



*** BUCKET BUMPER 5000332**

OEM No. 233-0734

FULL HANDRAIL SET TO SUIT CAT LOADER 2900 - PART NO: 5001786

*** NOT INCLUDED IN FULL SET**

CAT2900 Loader

CAT2900 Door

To suit Caterpillar 2900 JLK Machines
OEM No. 249-6759

* **Part No. 5001791**

Benefits include:

- Heavy duty construction
- Significant savings which takes away the need for downtime while repairing damaged doors
- Can be supplied with seals and glass
- Precision manufactured for fast fit up to your machine



TAILSHAFT GUARD BOTTOM 5001947

OEM No. 248-5140



TAILSHAFT GUARD TOP 5001948

OEM No. 248-5139

CAT2900 Folding Guards

Made to suit CAT 2900 Loaders, our fender acts as a wheel guard and is designed to withstand the harshest underground mining environments.

Benefits include:

- Heavy duty hinged folding system
- Double pin design to eliminate sagging
- No need to take off the fender when servicing behind the wheel guard
- Stainless pins with greasing points
- Patent pending



CAT2900 Dog Bone

Bend-tech's Dog Bone components are precision manufactured and machined from high tensile steel, with hardened and ground bushes. To suit OEM No. 186-9869

*** Part No. 5001783**

Benefits include:

- Constructed in one piece to increase strength
- Grease channels underneath to prevent rock damage
- Grease channel machined into the dogbone body
- Patent pending

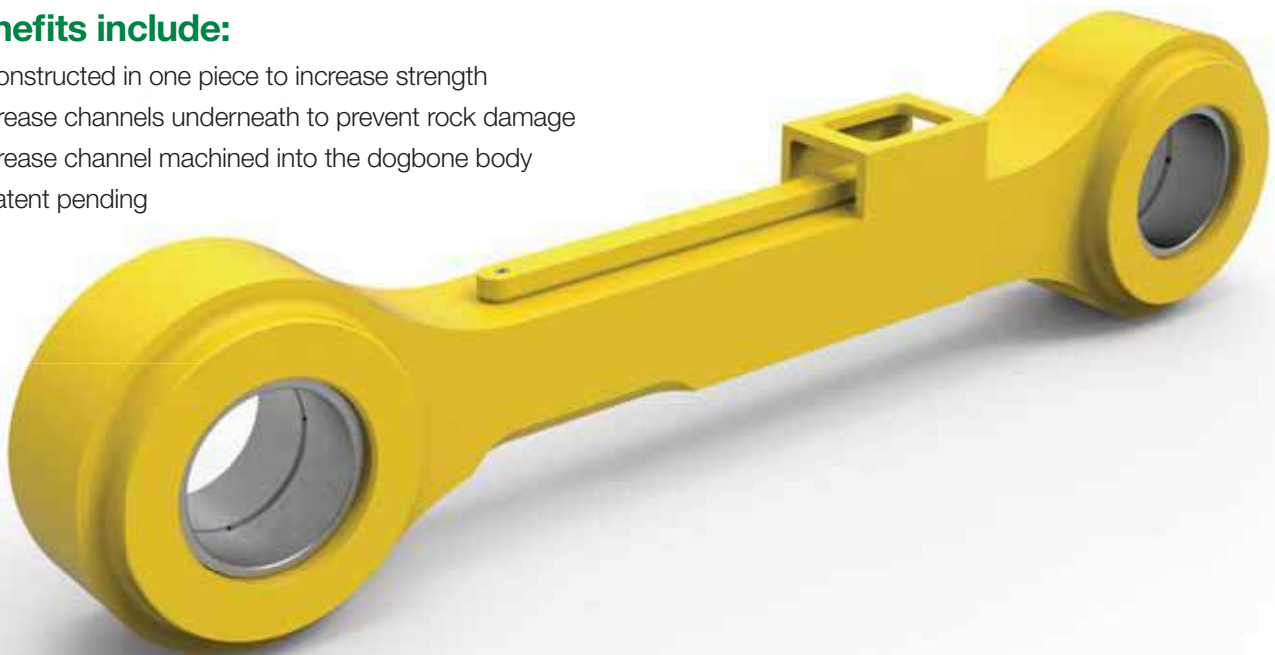

*** NOT INCLUDED IN FULL SET**

CAT3000 Loader

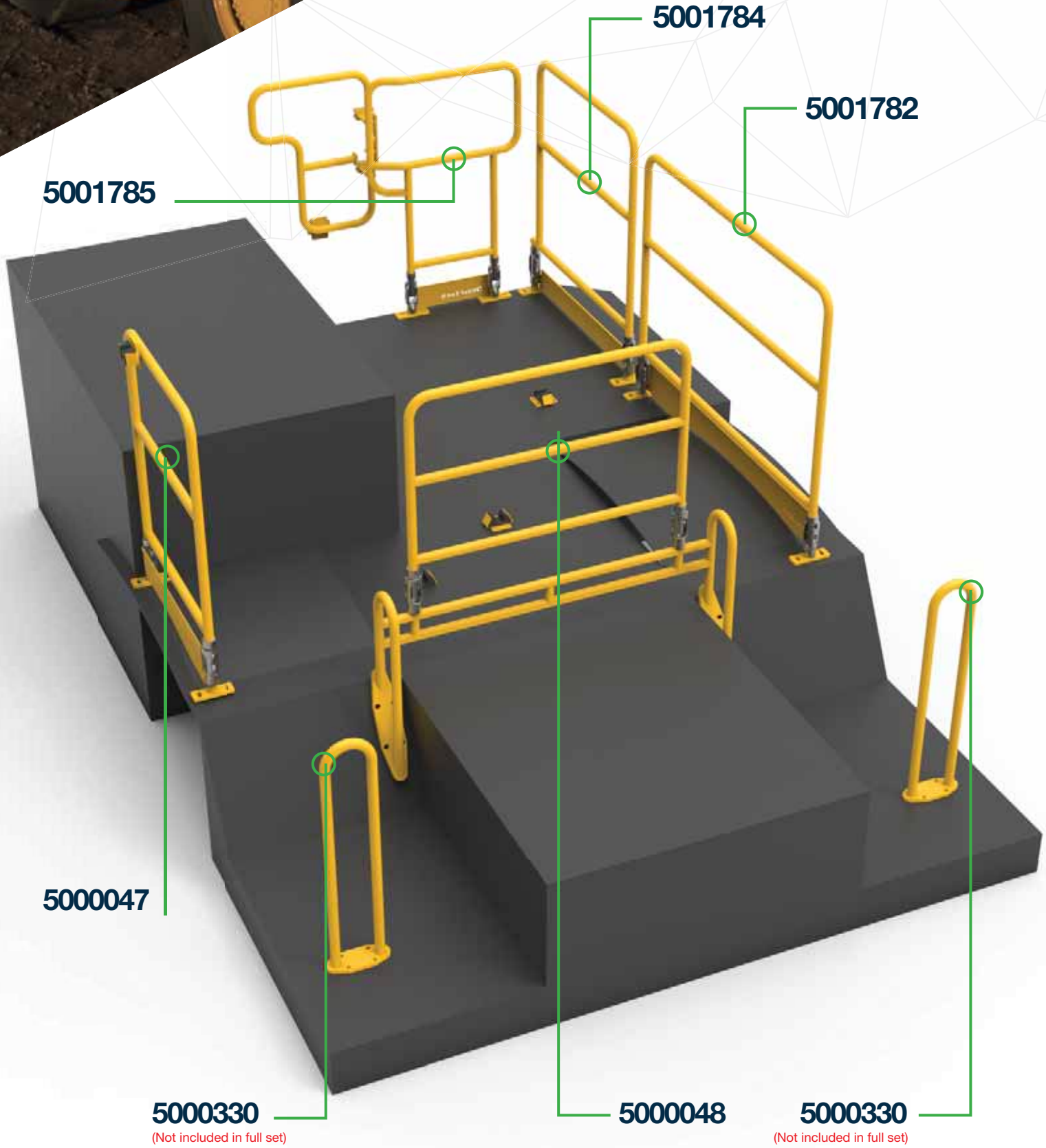

CAT3000 Loader



HANDRAIL 5001782
OEM No. 453-8703 (OLD 321-4739)



HANDRAIL 5000047
OEM No. 453-8705 (OLD 321-4745)



HANDRAIL 5000048
OEM No. 452-8704 feet attached (OLD 321-4753)



HANDRAIL 5001784
OEM No. 453-8702 (OLD 321-4758)



HANDRAIL 5001785
OEM No. 453-8701 (OLD 321-4767)



*** HANDRAIL 5000330**
OEM No. 230-9812

FULL HANDRAIL SET TO SUIT CAT LOADER 3000 - PART NO: 5001786



*** NOT INCLUDED IN FULL SET**

CATAD30 Truck

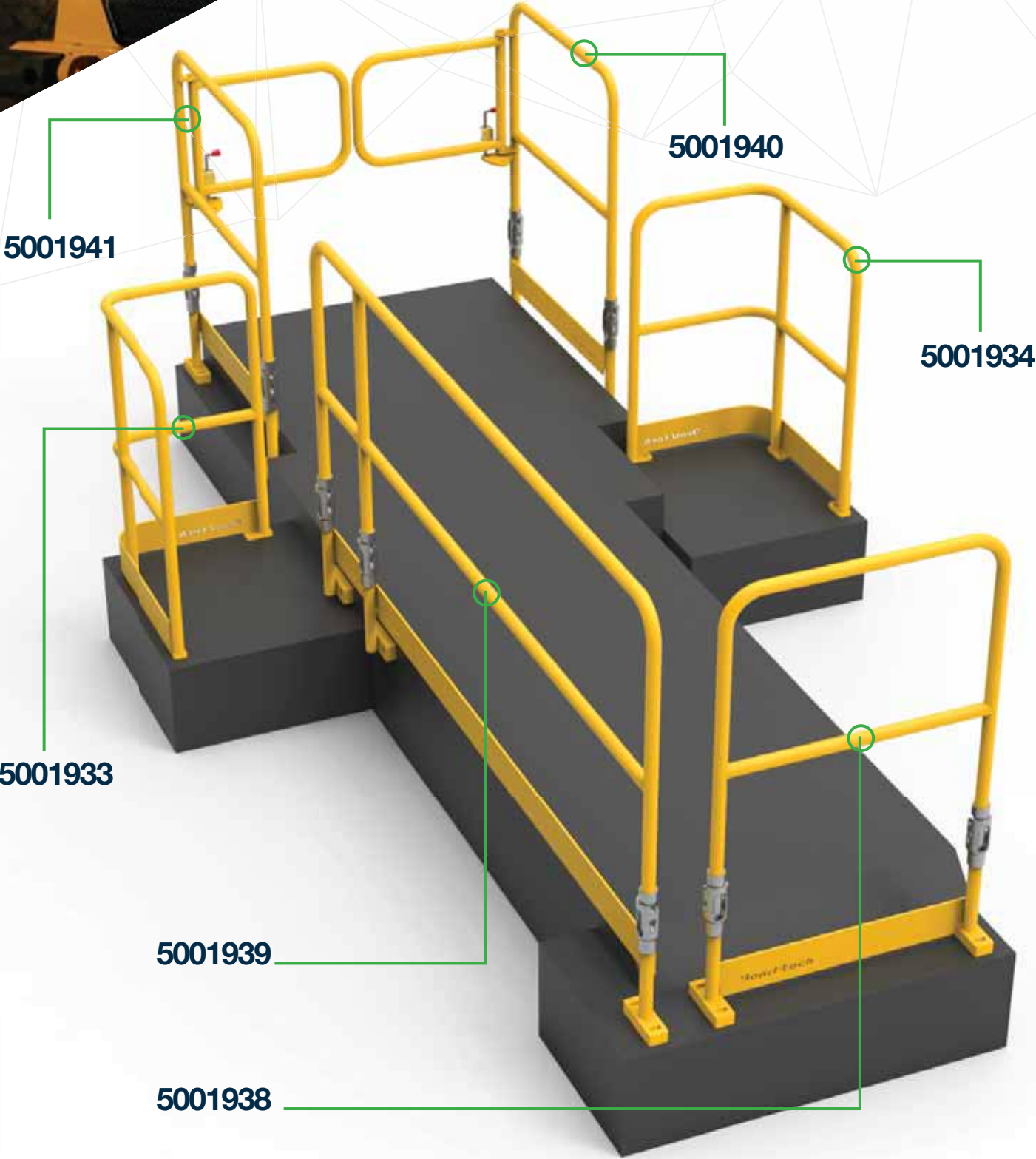

CAT **AD30** TRUCK



FRONT HANDRAIL 5001938



LH REAR HANDRAIL 5001941



RH REAR HANDRAIL 5001940



RH FRONT HANDRAIL 5001939

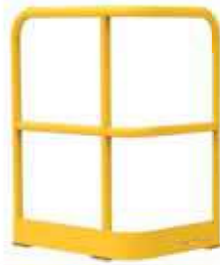

LH OUTER HANDRAIL 5001933



RH OUTER HANDRAIL 5001934

FULL HANDRAIL SET TO SUIT CAT TRUCK AD30 - NO: 5001960



*** NOT INCLUDED IN FULL SET**

CATAD45 Truck

5001923

5001924

5000056

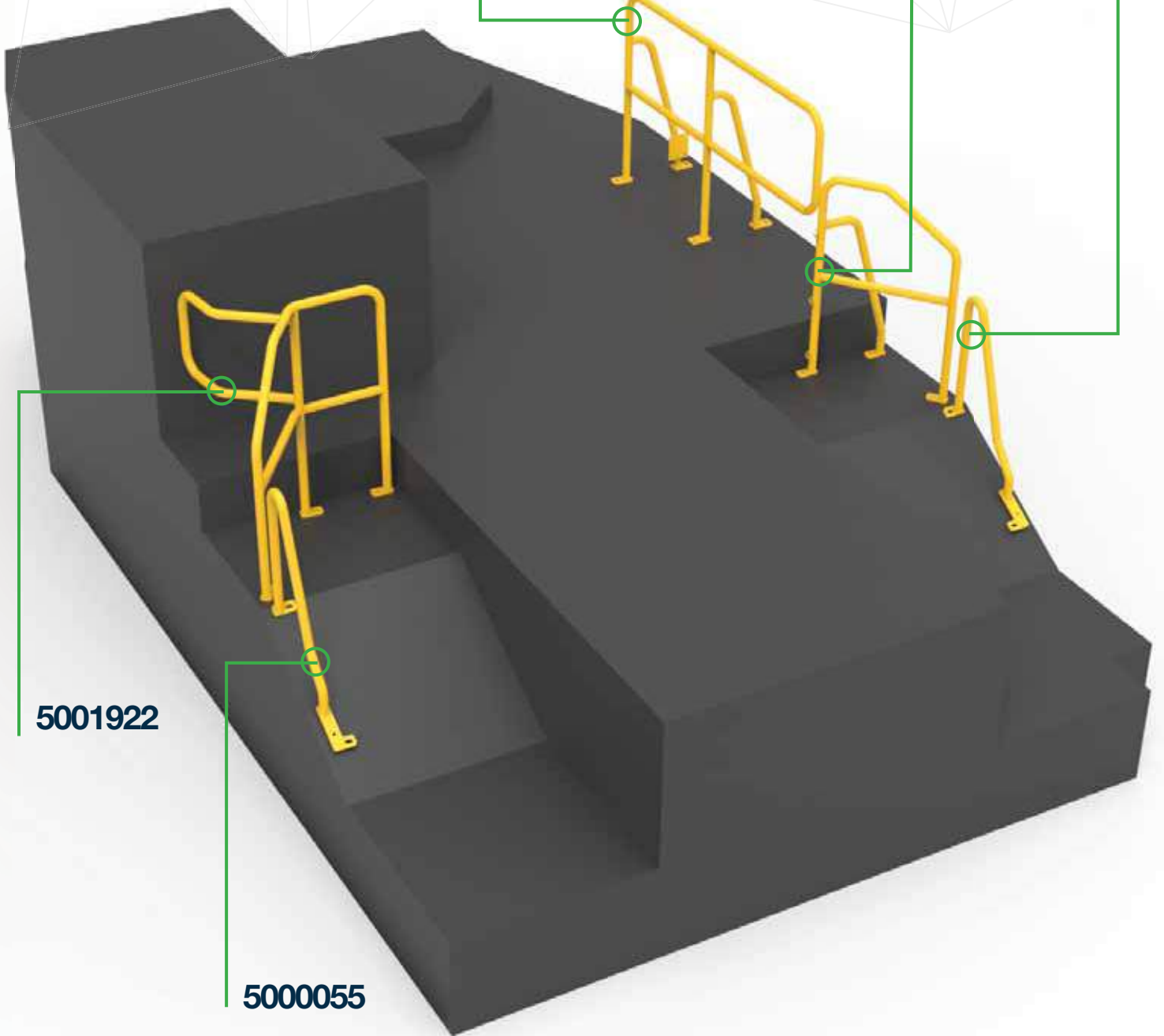

5001922

5000055

CAT **AD45** TRUCK



HANDRAIL 5000055
OEM No. 245-2160



HANDRAIL 5000056
OEM No. 245-2161



HANDRAIL 5001922
OEM No. 271-1840



HANDRAIL 5001923
OEM No. 271-1841



HANDRAIL 5001924
OEM No. 271-1842



*** BUMPER 5001935**
OEM No. 166-4225 (single unit)

FULL HANDRAIL SET TO SUIT CAT TRUCK AD45 - PART NO: 5001925



*** NOT INCLUDED IN FULL SET**

CAT AD55 DNW Truck

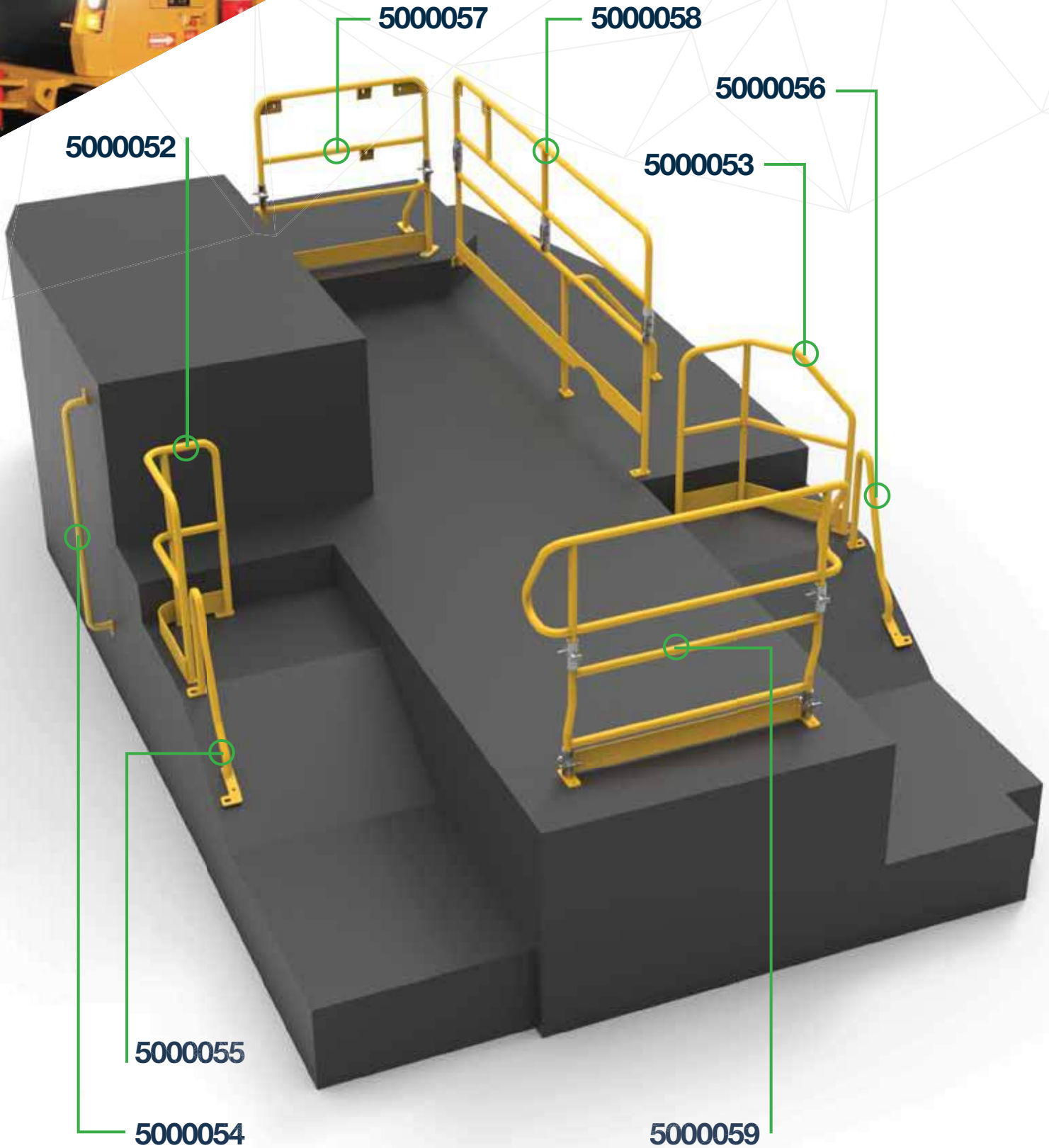

CAT **AD55-DNW** TRUCK



HANDRAIL 5000052
OEM No. 211-3320



HANDRAIL 5000053
OEM No. 211-3321



HANDRAIL 5000054
OEM No. 211-3328



HANDRAIL 5000055
OEM No. 245-2160



HANDRAIL 5000056
OEM No. 245-2161



HANDRAIL 5000057
OEM No. 321-4800 Offset Feet



HANDRAIL 5000058
OEM No. 361-8490



HANDRAIL 5000059
OEM No. 316-2954



*** BUMPER 5001935**
OEM No. 166-4225 (single unit)

FULL HANDRAIL SET TO SUIT CAT TRUCK AD55-DNW - PART NO: 5000060

CAT AD55 JNW Truck

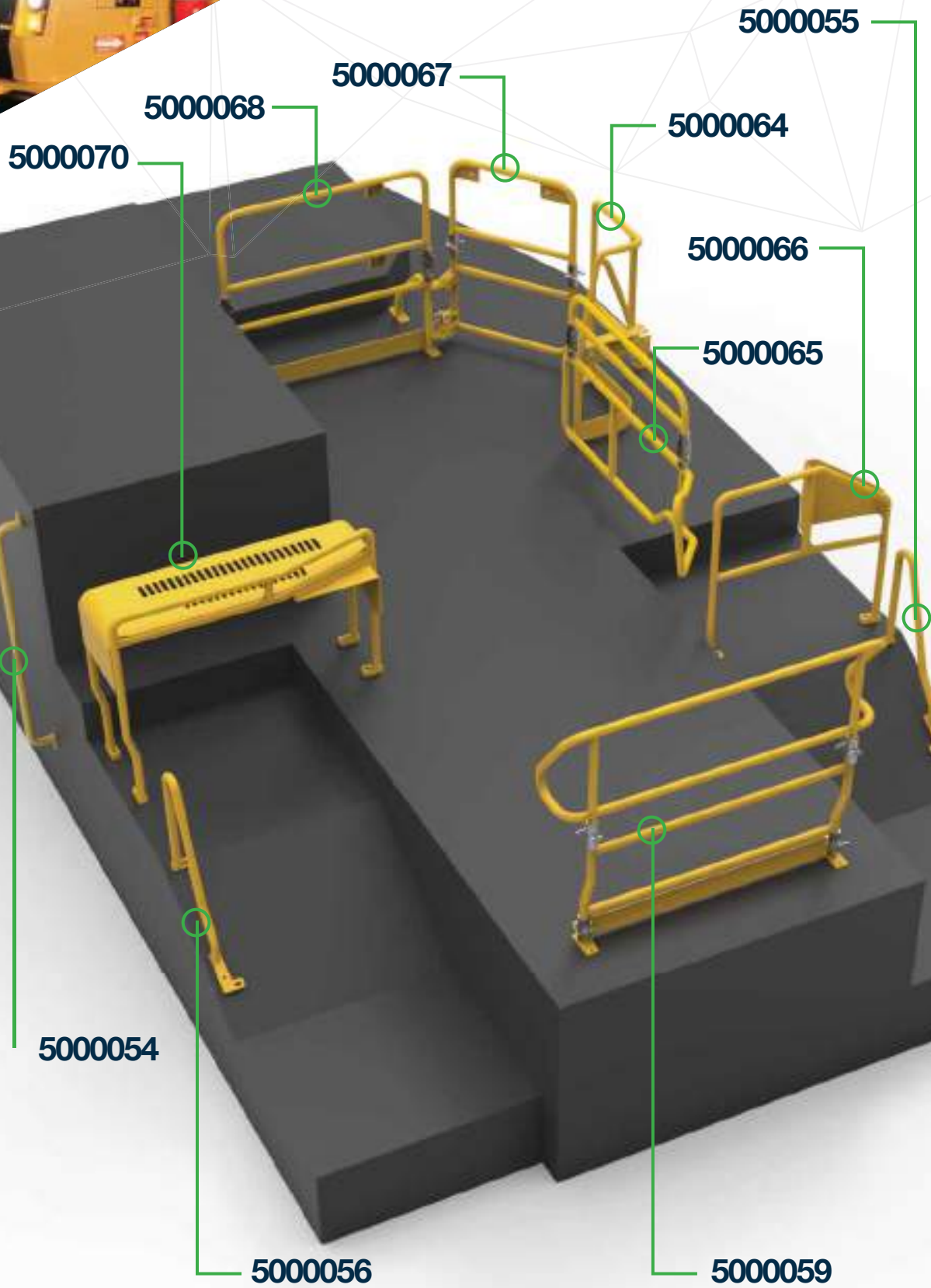

CAT **AD55B-JNW** TRUCK



HANDRAIL 5000054
OEM No. 211-3328



HANDRAIL 5000055
OEM No. 245-2160



HANDRAIL 5000056
OEM No. 245-2161



HANDRAIL 5000064
OEM No. 304-6145



HANDRAIL 5000065
OEM No. 313-2827



HANDRAIL 5000066
OEM No. 304-6148



HANDRAIL 5000067
OEM No. 313-3123



HANDRAIL 5000068
OEM No. 313-3146 Straight Feet



HANDRAIL 5000059
OEM No. 316-2954



HANDRAIL 5000070
OEM No. 310-4990



*** LADDER 5000046**
OEM No. 338-6547



*** BUMPER 5001935**
OEM No. 166-4225 (single unit)

FULL HANDRAIL SET TO SUIT CAT TRUCK AD55-JNW - PART NO: 5000071

*** NOT INCLUDED IN FULL SET**

CATAD60-KNW Truck

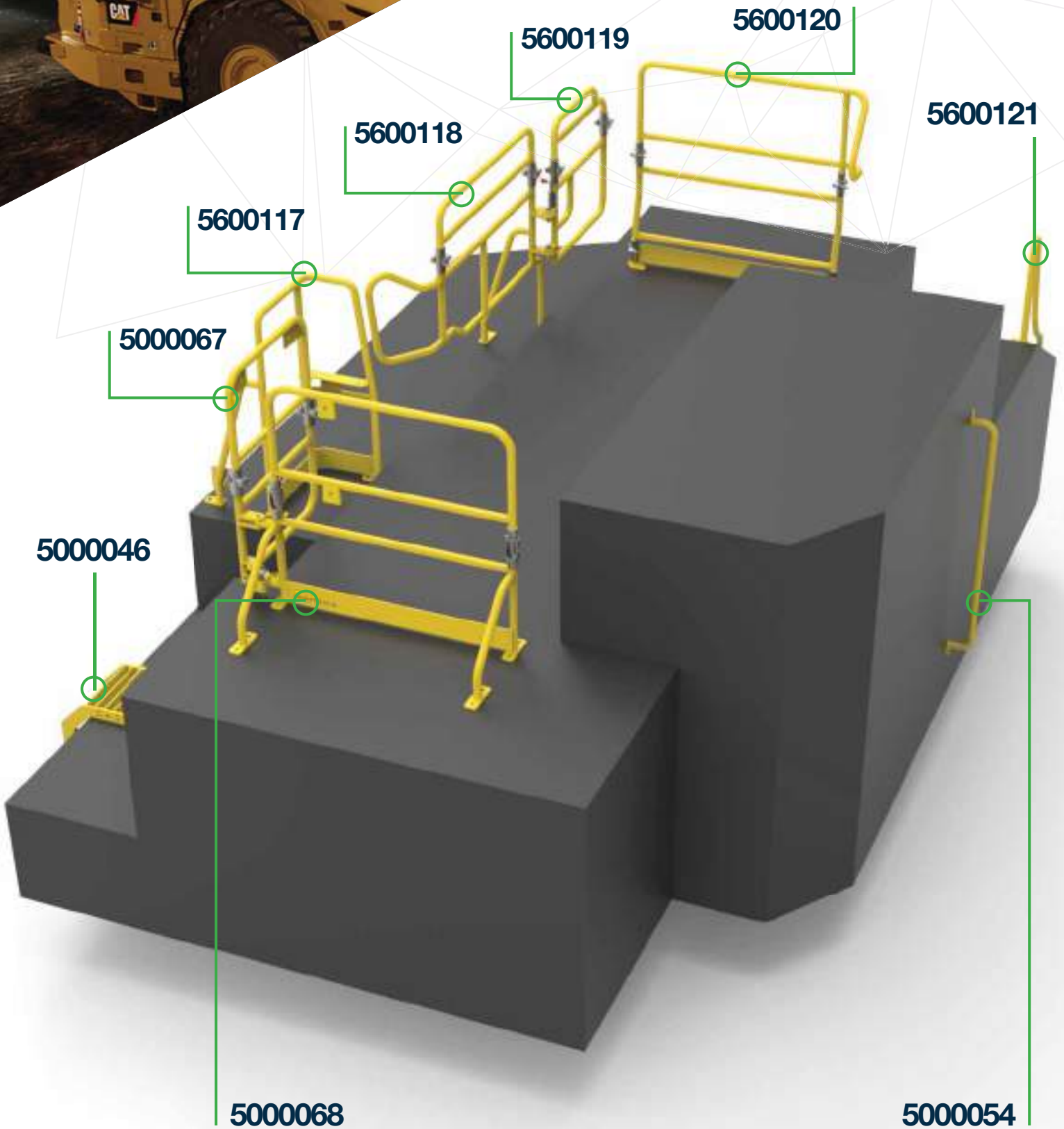

CAT **AD60-KNW** TRUCK



HANDRAIL 5000054
OEM No. 211-3328



HANDRAIL 5000067
OEM No. 313-3123



HANDRAIL 5000068
OEM No. 313-3146



HANDRAIL 5600118
OEM No. 393-5365



HANDRAIL 5600117
OEM No. 366-4160



HANDRAIL 5600119
OEM No. 393-5385



HANDRAIL 5600120
OEM No. 370-2776



*** HANDRAIL 5600121**
OEM No. 380-0075



*** LADDER 5000046**
OEM No. TBA



*** BUCKET BUMPER 5000332**
OEM No. 233-0734

FULL HANDRAIL SET TO SUIT CAT TRUCK AD60-KNW - PART NO: 5600122

*** NOT INCLUDED IN FULL SET**

Epiroc/Atlas MT42 Truck

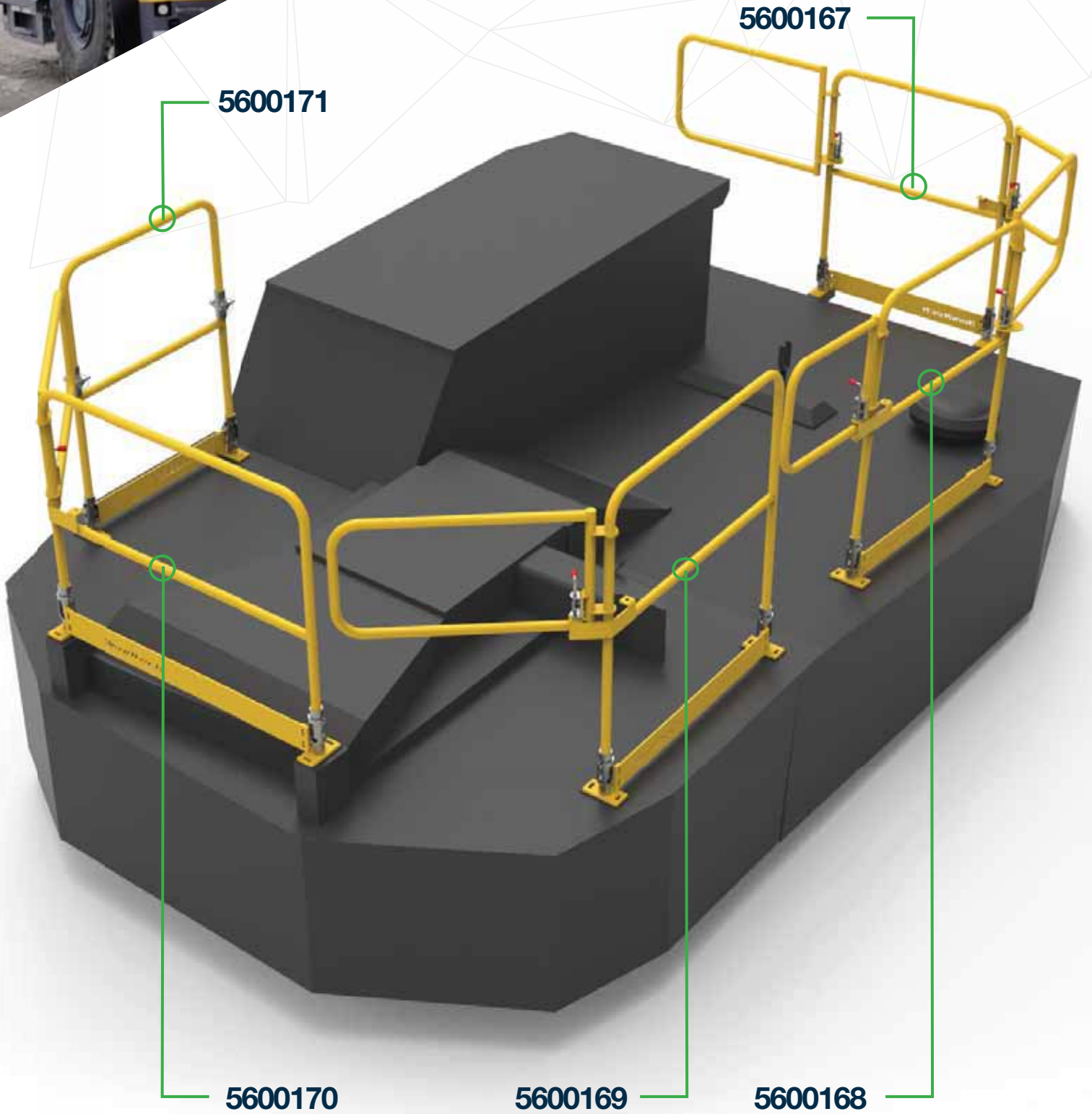

Epiroc/Atlas **MT42** TRUCK



HANDRAIL 5600167



HANDRAIL 5600168



HANDRAIL 5600169



HANDRAIL 5600170



HANDRAIL 5600171

FULL HANDRAIL SET TO SUIT EPIROC/ATLAS MT42 FULL SET - PART NO: 5600172



*** NOT INCLUDED IN FULL SET**

Epiroc/Atlas MT54 Truck

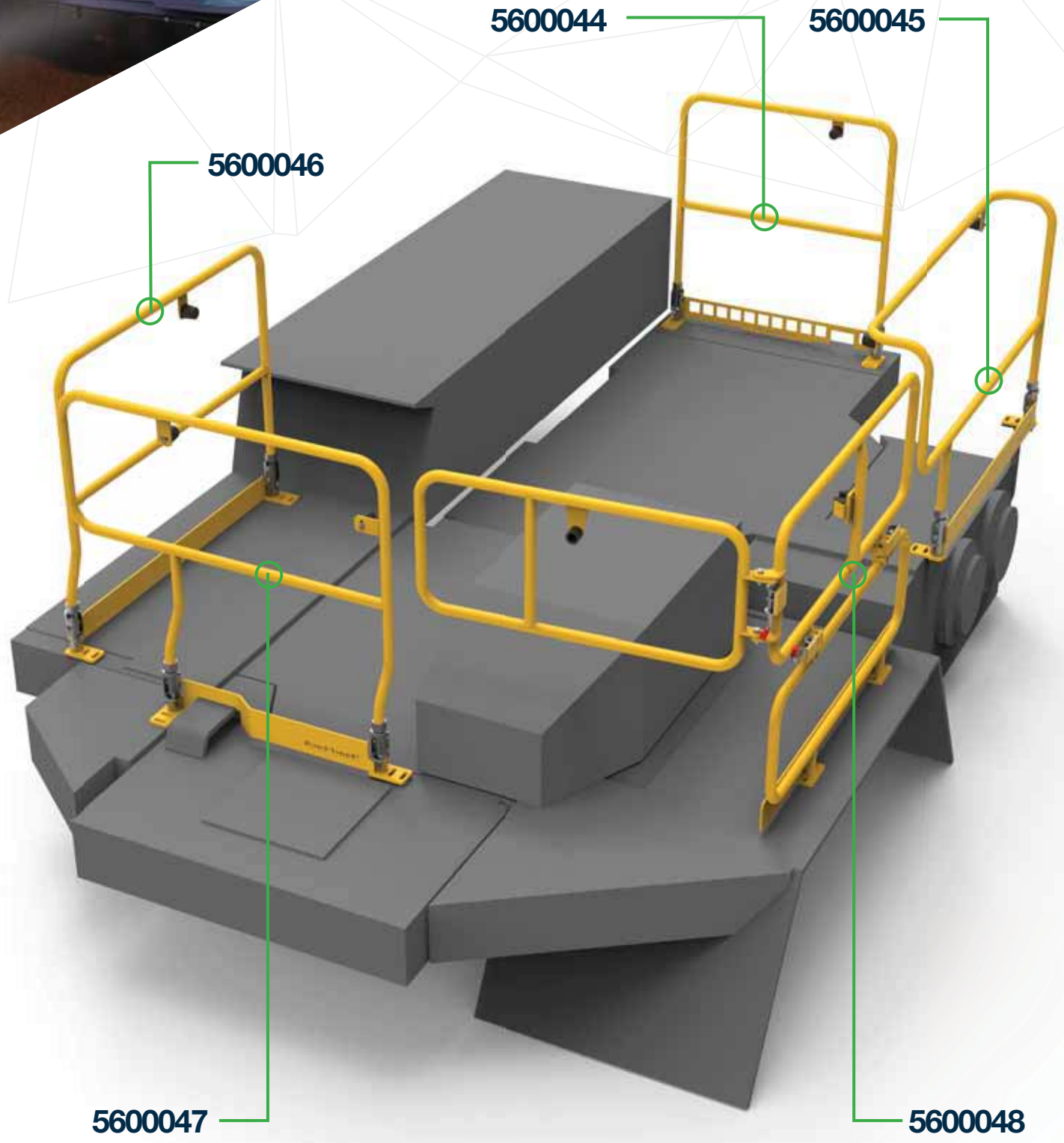

Epiroc/Atlas **MT54** TRUCK



HANDRAIL 5600044
TO SUIT MT65 TRUCK – FRONT



HANDRAIL 5600045
TO SUIT MT65 TRUCK – RH FRONT



HANDRAIL 5600046
TO SUIT MT65 TRUCK – LH REAR



HANDRAIL 5600047
TO SUIT MT65 TRUCK – REAR



HANDRAIL 5600048 TO SUIT MT65
TRUCK – EXHAUST HANDRAIL

FULL HANDRAIL SET TO SUIT EPIROC/ATLAS MT54 TRUCK PART NO. 5600049



*** NOT INCLUDED IN FULL SET**

Epiroc/Atlas MT65 Truck

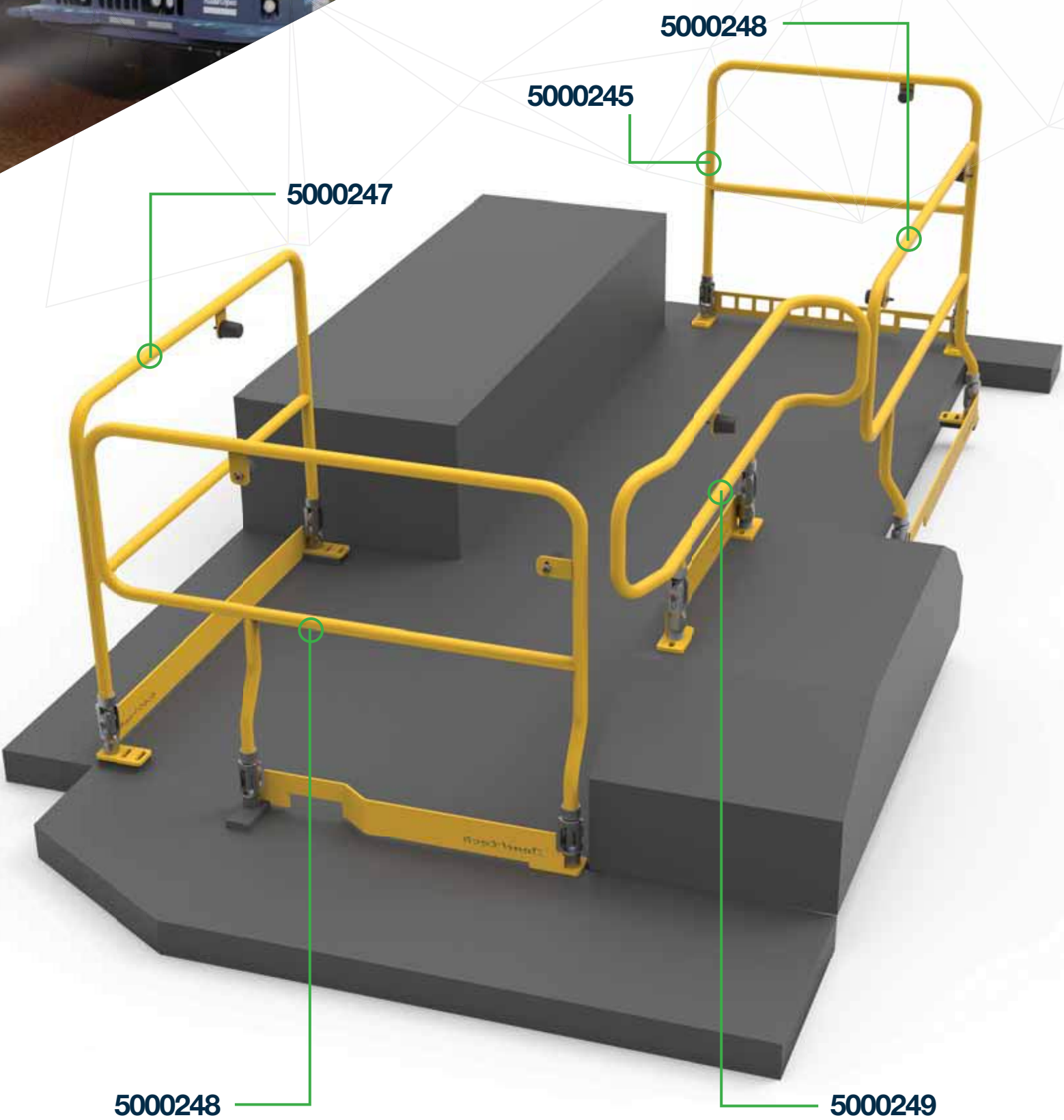

5000248

5000245

5000247

5000248

5000249

Epiroc/Atlas **MT65** TRUCK



FULL HANDRAIL SET TO SUIT EPIROC/ATLAS MT65 FULL - PART NO: 5000250



*** NOT INCLUDED IN FULL SET**

Epiroc/Atlas MT65 Truck - 2017 BEYOND

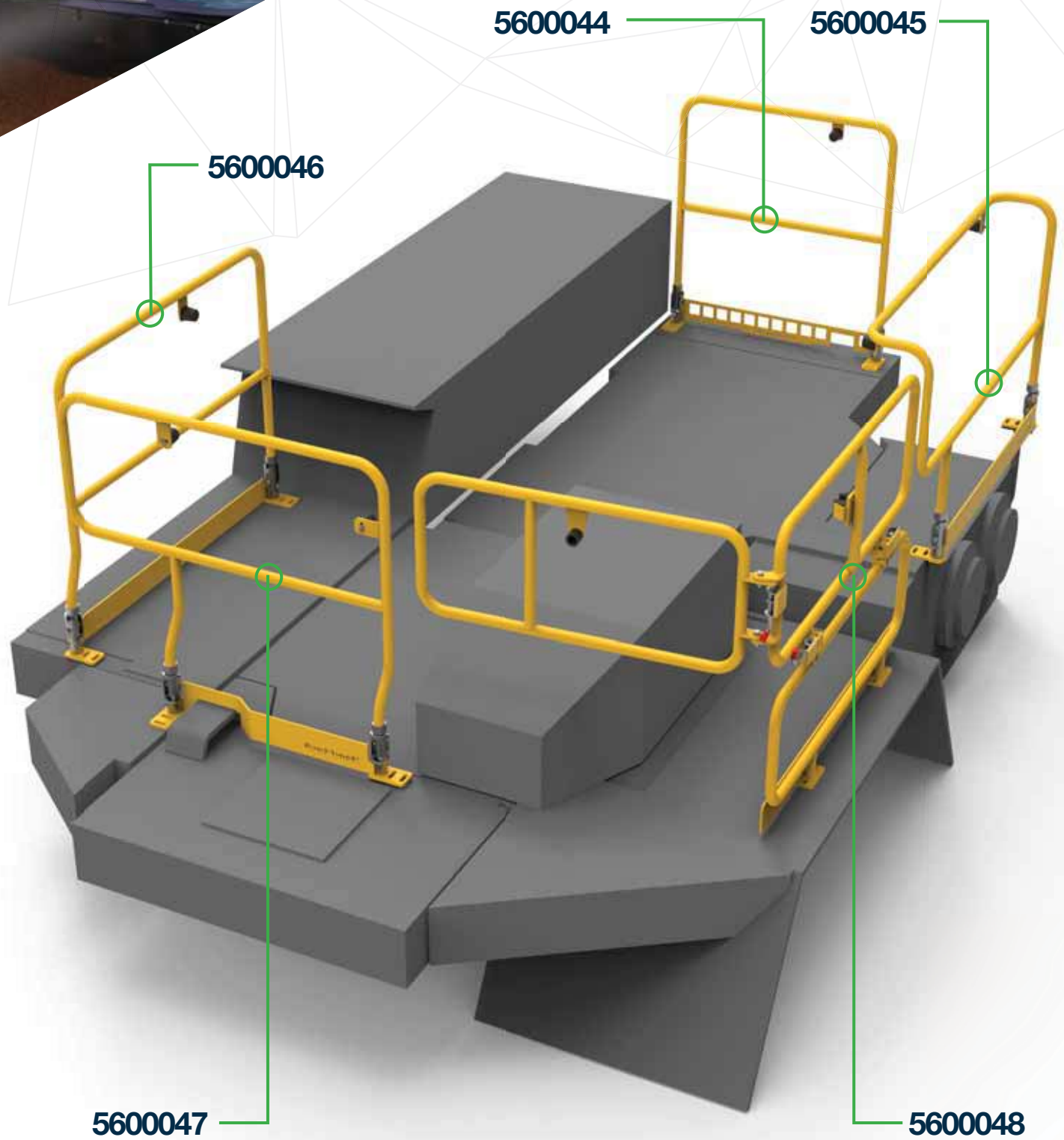

Epiroc/Atlas **MT65** TRUCK - 2017 BEYOND



HANDRAIL 5600044
TO SUIT MT65 TRUCK - FRONT



HANDRAIL 5600045
TO SUIT MT65 TRUCK - RH FRONT



HANDRAIL 5600046
TO SUIT MT65 TRUCK - LH REAR



HANDRAIL 5600047
TO SUIT MT65 TRUCK - REAR



HANDRAIL 5600048
TO SUIT MT65 TRUCK - EXHAUST HANDRAIL



RAM CLAMP 5503172
8T WLL EACH SET

FULL HANDRAIL SET TO SUIT EPIROC/ATLAS MT65 - 2017 BEYOND TRUCK PART NO: 55600049

*** NOT INCLUDED IN FULL SET**

Epiroc/Atlas MT2010

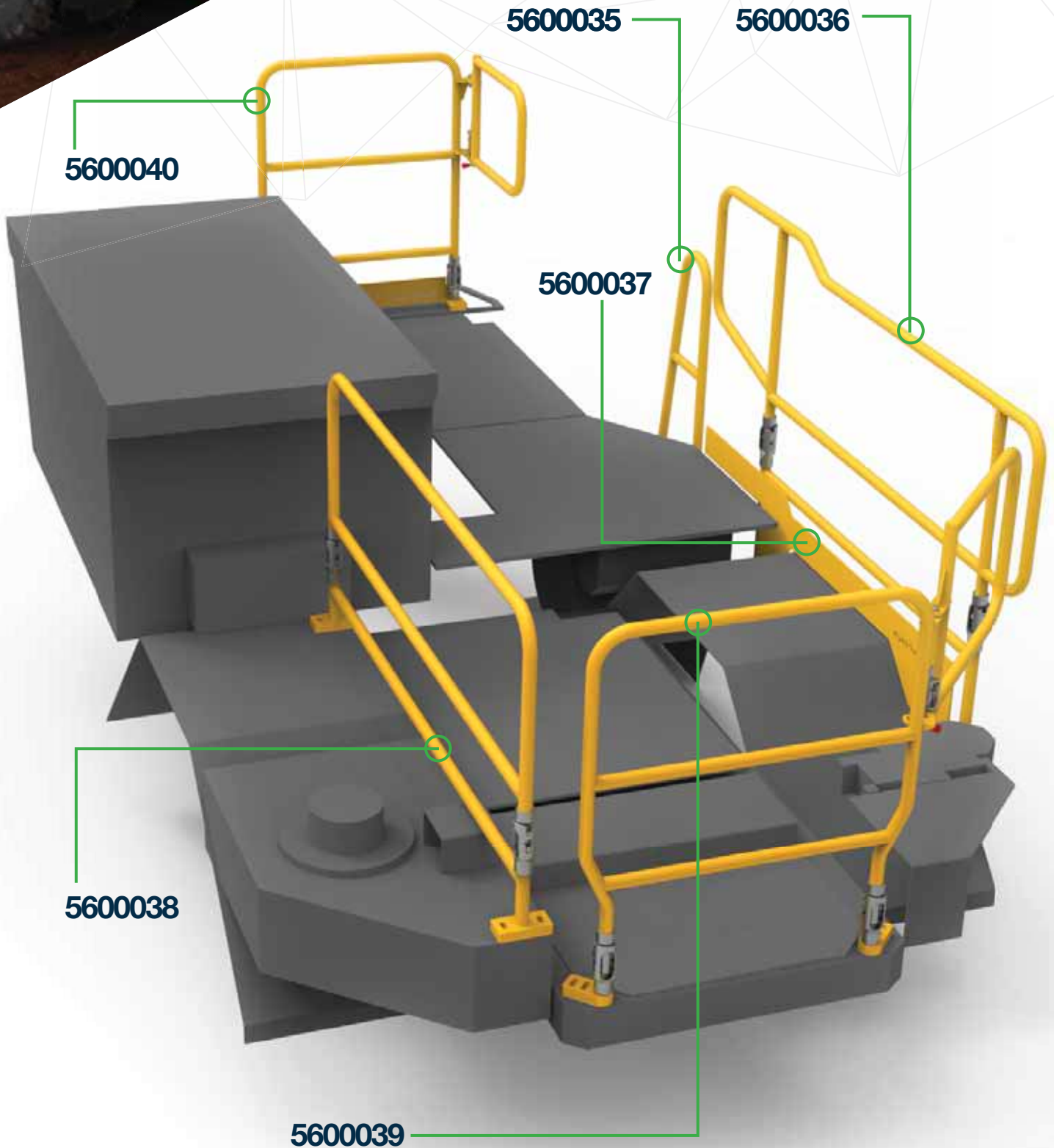

Epiroc/Atlas **MT2010** TRUCK



HANDRAIL 5600035



HANDRAIL 5600036



HANDRAIL 5600037



HANDRAIL 5600038



HANDRAIL 5600039



HANDRAIL 5600040

FULL HANDRAIL SET TO SUIT EPIROC/ATLAS MT2010 TRUCK - PART NO. 5600050



*** NOT INCLUDED IN FULL SET**

Epiroc/Atlas MT6020 Truck - Tier 2

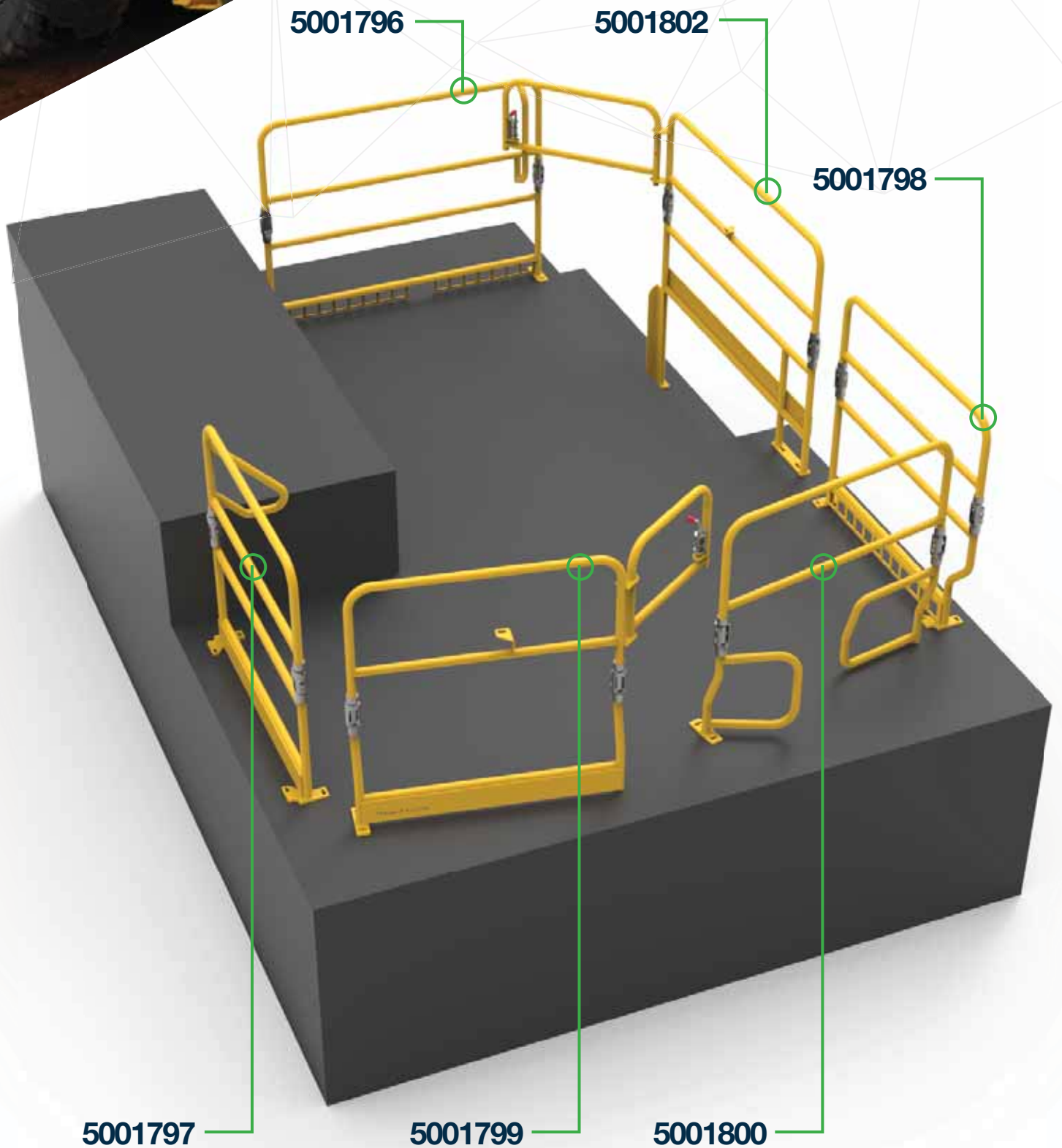

Epiroc/Atlas **MT5020** TRUCK



HANDRAIL 5001796



HANDRAIL 5001797



HANDRAIL 5001798



HANDRAIL 5001799



HANDRAIL 5001800



*** HANDRAIL 5001930**

* PLEASE NOTE: THESE HANDRAIL IS DESIGNED FOR TRUCK THAT HAS RENCOOL AIR CON UNIT FITTED



HANDRAIL 5001802



RAM CLAMP 5502784

8T WLL EACH SET

FULL HANDRAIL SET TO SUIT EPIROC/ATLAS MT5020 - PART NO: 5001804

*** NOT INCLUDED IN FULL SET**

Epiroc/Atlas MT6020 Truck - Tier 2

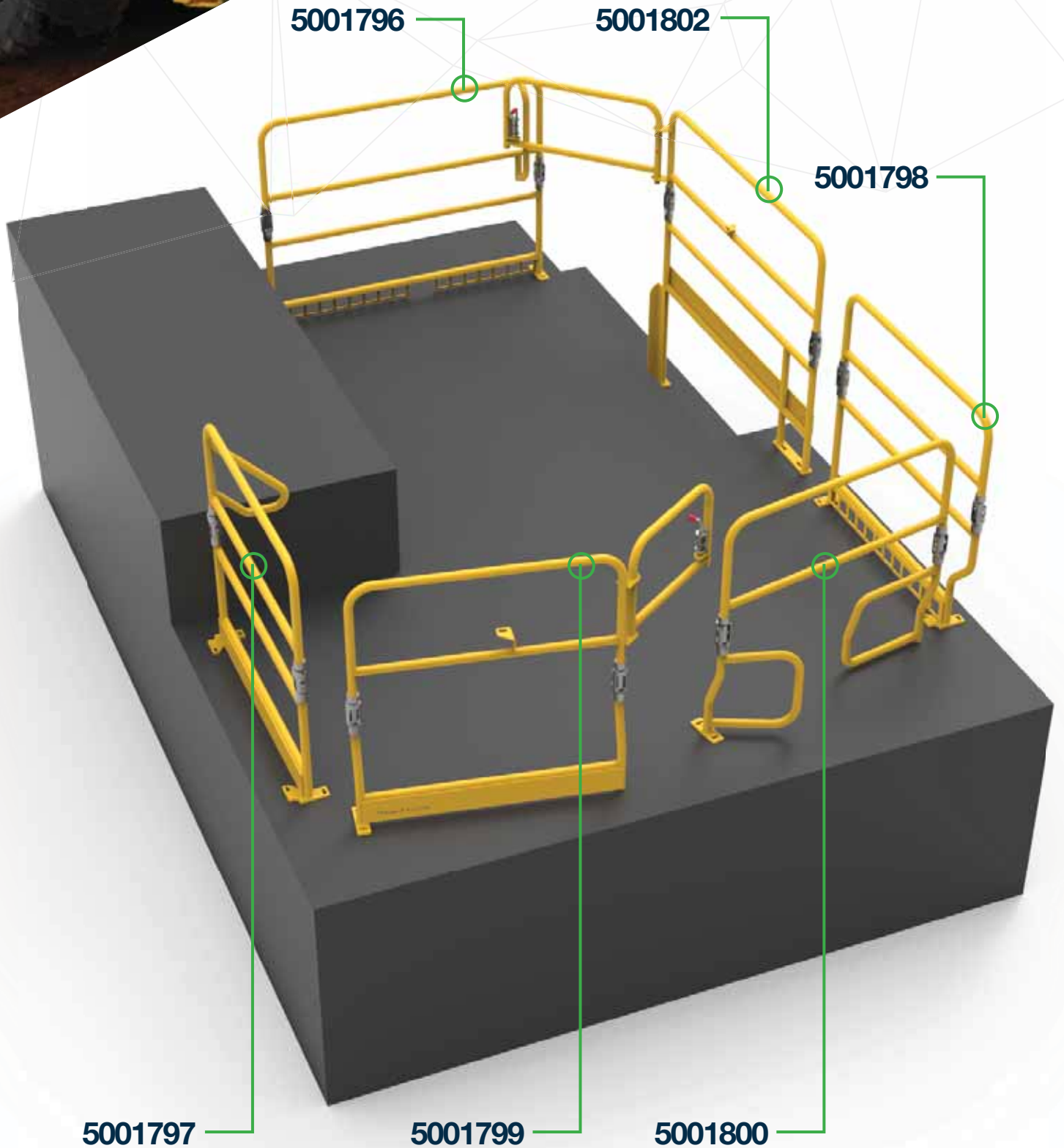

Epiroc/Atlas **MT6020 TIER 2** TRUCK



HANDRAIL 5001796



HANDRAIL 5001797



HANDRAIL 5001798



HANDRAIL 5001799



HANDRAIL 5001800



*** HANDRAIL 5001930**

* PLEASE NOTE: THESE HANDRAIL IS DESIGNED FOR TRUCK THAT HAS RENCOOL AIR CON UNIT FITTED



HANDRAIL 5001802



RAM CLAMP 5502784

8T WLL EACH SET

FULL HANDRAIL SET TO SUIT EPIROC/ATLAS MT6020 TIER 2 - PART NO: 5001804

*** NOT INCLUDED IN FULL SET**

SANDVIK LH514 Loader

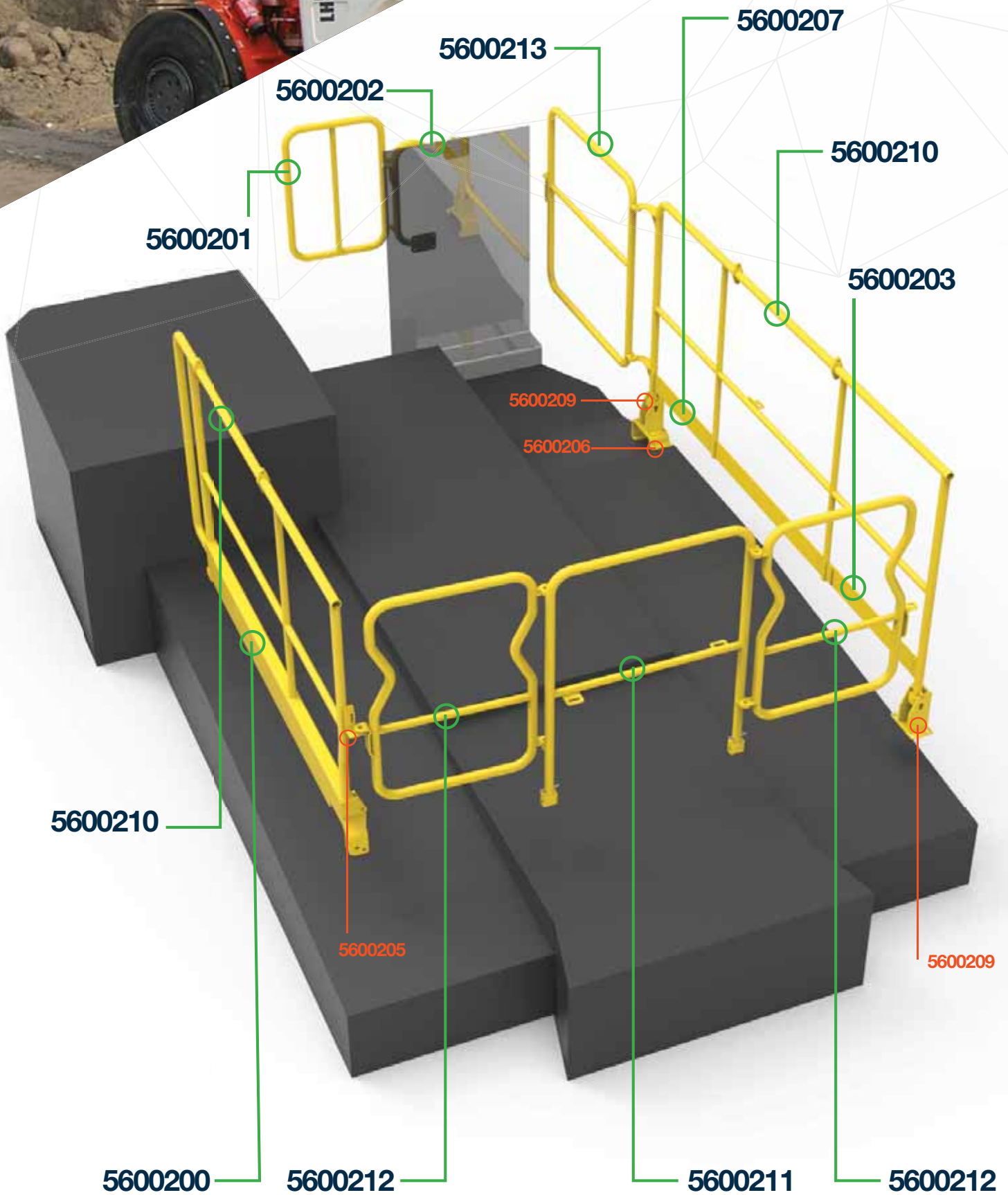

SANDVIK **LH514** LOADER



HANRAIL PART NO. 5600207
OEM No. 56027403

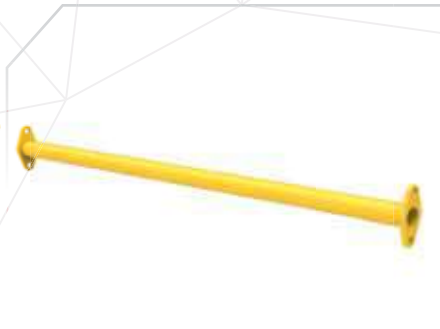

QTY 2 - HANRAIL PART NO. 5600210
OEM No. 56036363



HANRAIL PART NO. 5600213
OEM No. 56027443



HANRAIL PART NO. 5600202
OEM No. BG00612434



HANRAIL PART NO. 5600201
OEM No. BG00612435



HANRAIL PART NO. 5600211
OEM No. 56027408



QTY 2 - HANRAIL PART NO. 5600212
OEM No. 56027414



HANRAIL PART NO. 5600200
OEM No. OEM 56203320



QTY 1 - CONNECTOR PART NO. 5600205
OEM No. 56210789



QTY 2 - SUPPORTING BRACKET PART NO. 5600209
OEM No. 56027394

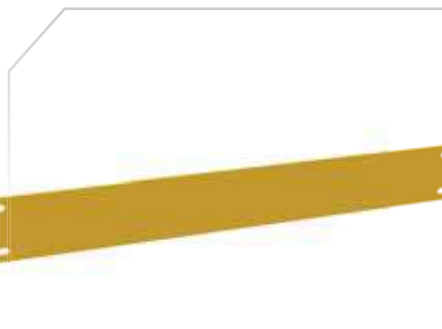

QTY 1 - KICKPLATE PART NO. 5600203
OEM No. BG00520886



QTY 1 - BRACKET PART NO. 5600206
OEM No. 56030702

*** NOT INCLUDED IN FULL SET**

SANDVIK LH517 Loader

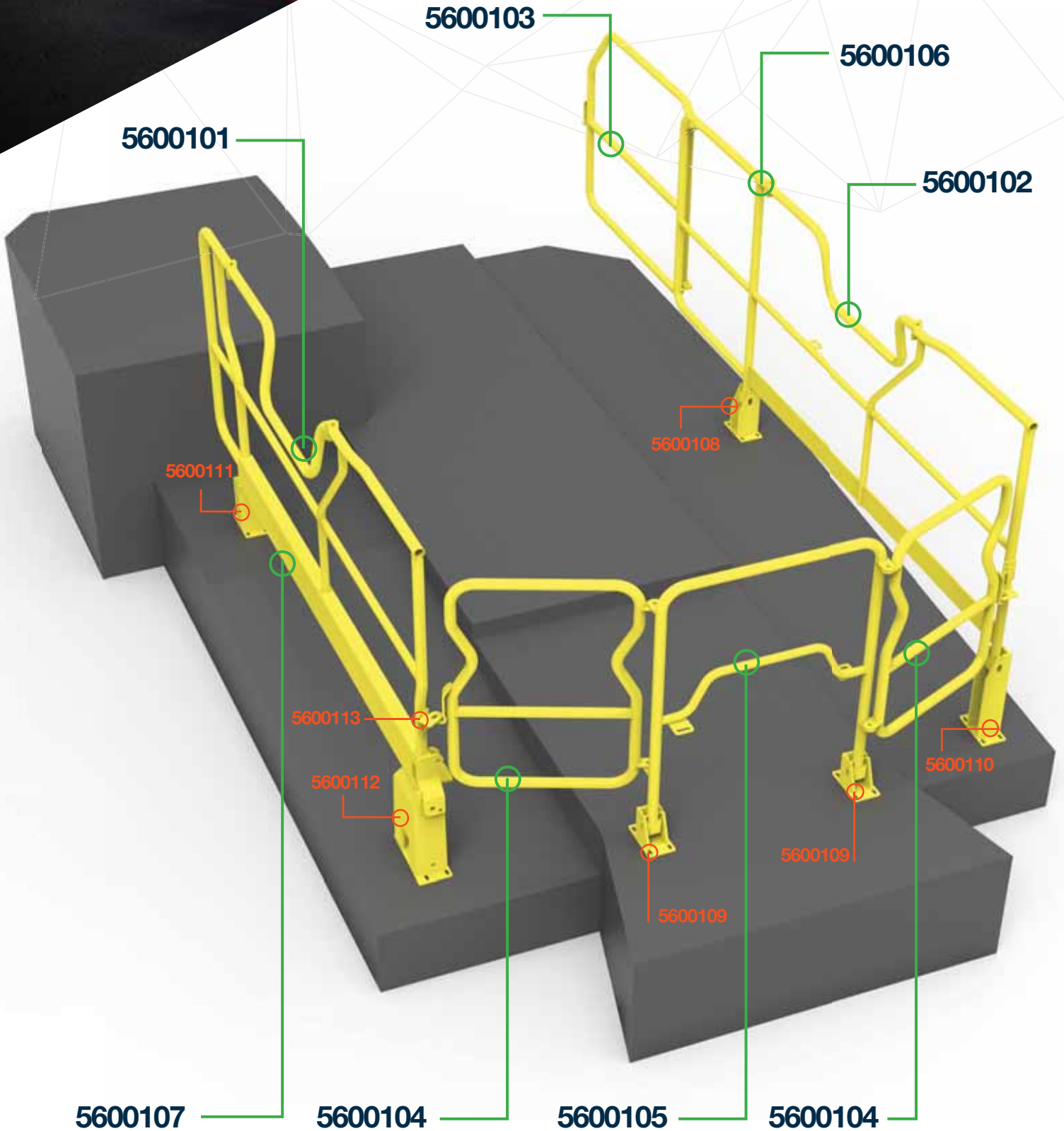

SANDVIK **LH517** LOADER



HANDRAIL 5600101
OEM No. 56039607

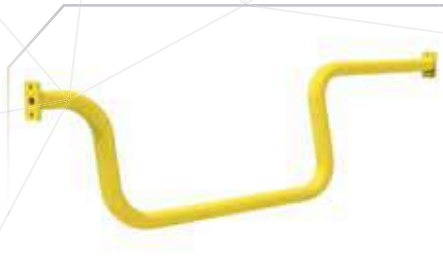

HANDRAIL 5600102
OEM No. 56039606



HANDRAIL 5600103
OEM No. 56039616



QTY 2 - HANDRAIL 5600104
OEM No. 56039582



HANDRAIL 5600105
OEM No. 56039619



HANDRAIL 5600106
OEM No. C56029393



HANDRAIL 5600107
OEM No. 56212200



QTY 1 - SUPPORTING BLOCK 5600108
OEM No. C56039673



QTY 2 - SUPPORTING BLOCK 5600109
OEM No. 56027411



QTY 1 - SUPPORTING BLOCK 5600110
OEM No. 56039676



QTY 1 - SUPPORTING BLOCK 5600111
OEM No. 56212216



QTY 1 - SUPPORTING BLOCK 5600112
OEM No. 56212346



QTY 1 - KIT COMPONENT 5600113
OEM No. 56029744

*** NOT INCLUDED IN FULL SET**

SANDVIK LH621 Loader

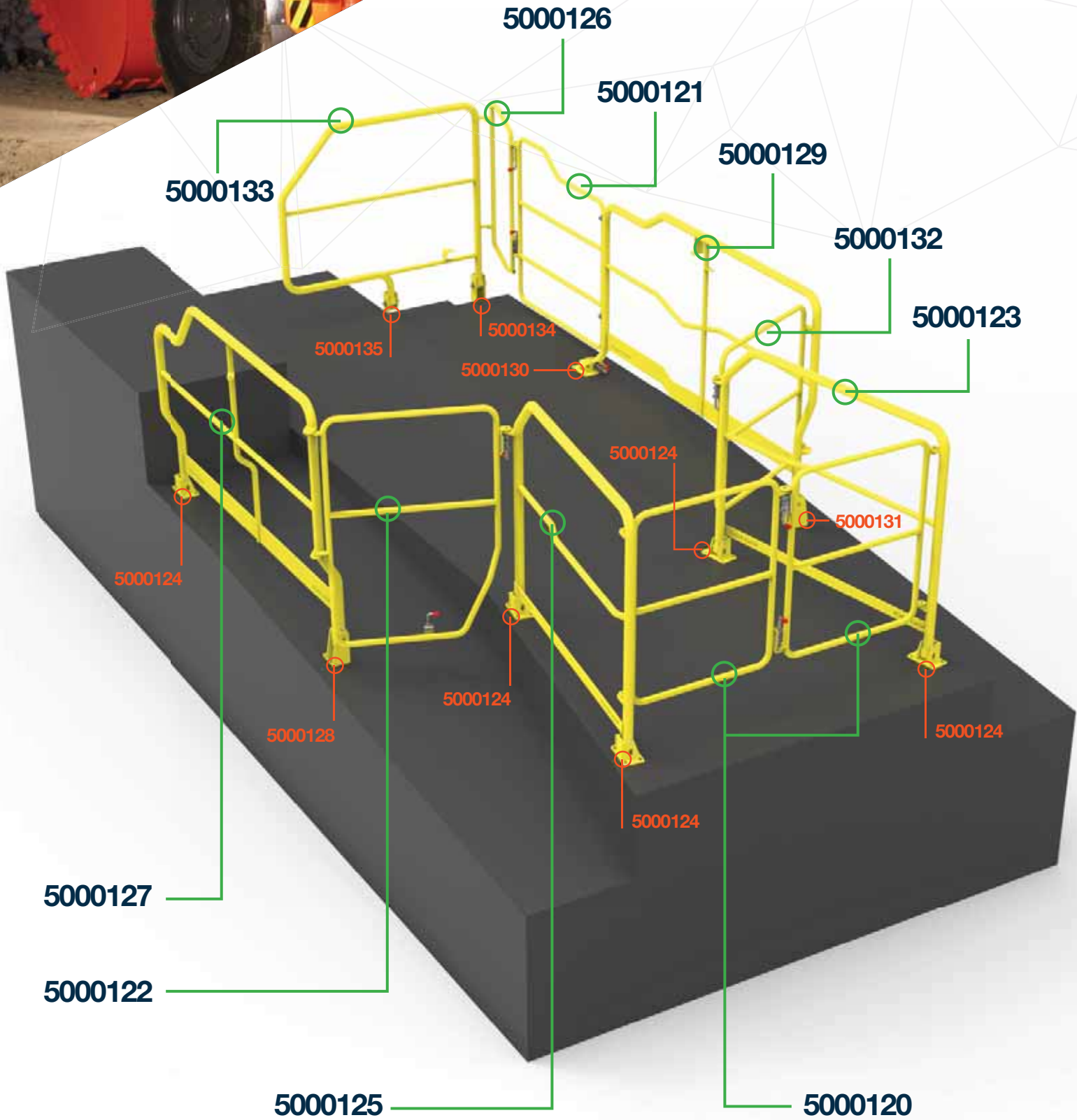

FULL HANDRAIL SET TO SUIT SANDVIK LH621 LOADER - PART NO: 5000141

SANDVIK **LH621** LOADER



HANDRAIL 5000120
OEM No. 56018767



HANDRAIL 5000121
OEM No. 56018768



HANDRAIL 5000133
OEM No. 56018764



HANDRAIL 5000123
OEM No. 56018762



HANDRAIL 5000125
OEM No. 56018761

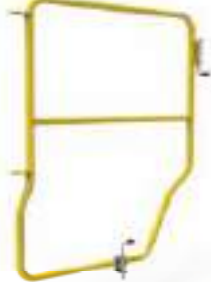

HANDRAIL 5000122
OEM No. 56018765



HANDRAIL 5000127
OEM No. 56018760



HANDRAIL 5000129
OEM No. 56018763



HANDRAIL 5000132
OEM No. 56018766



HANDRAIL 5000126
OEM No. 56019161



QTY 1 - SUPPORT BRACKET 5000135
OEM No. 56018774



QTY 1 - SUPPORT BRACKET 5000134
OEM No. 56018773



QTY 1 - SUPPORT BRACKET 5000131
OEM No. 56018771



QTY 1 - SUPPORT BRACKET 5000128
OEM No. 56018770



QTY 5 - SUPPORT BRACKET 5000124
OEM No. 56018769



QTY 1 - SUPPORT BRACKET 5000130
OEM No. 56018772

*** NOT INCLUDED IN FULL SET**

SANDVIK LH621 Hydraulic Handrails

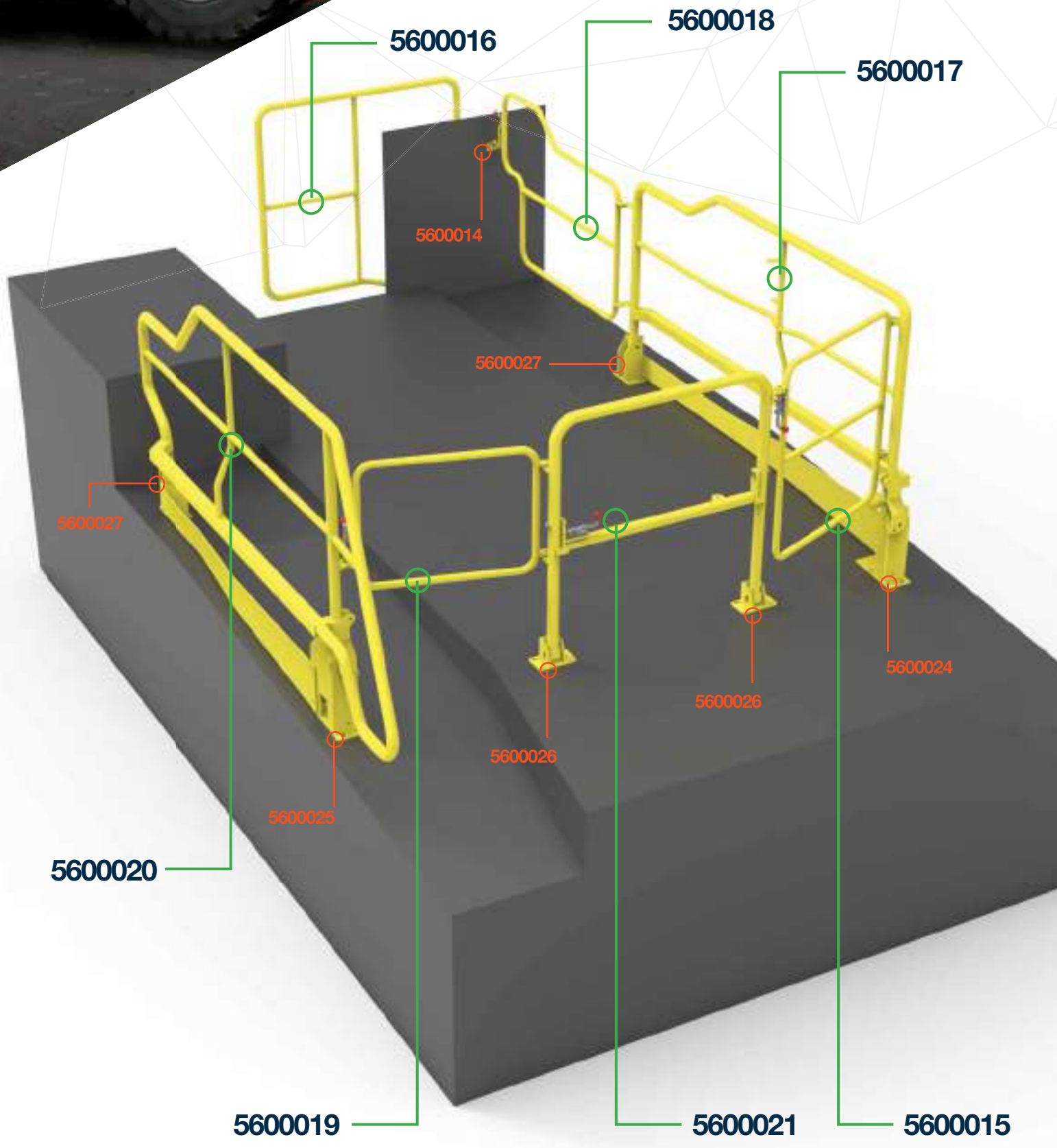

SANDVIK **LH621** Hydraulic Handrails



HANDRAIL 5600015
OEM No. BG00311924



HANDRAIL 5600016
OEM No. BG00311588



HANDRAIL 5600017
OEM No. BG00311830



HANDRAIL 5600018
OEM No. BG00311904



HANDRAIL 5600019
OEM No. BG00313074



HANDRAIL 5600020
OEM No. BG00313079



HANDRAIL 5600021
OEM No. BG00353239

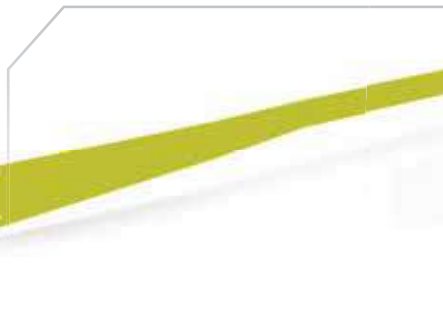

KICKPLATE 5600022
OEM No. BG00313347



KICKPLATE 5600023
OEM No. BG00319454



**QTY 1 - SUPPORT
BRACKET 5600014**
OEM No. 56039625



**QTY 1 - SUPPORT
BRACKET 5600024**
OEM No. BG00312309



**QTY 1 - SUPPORT
BRACKET 5600025**
OEM No. 56212346



**QTY 2 - SUPPORT
BRACKET 5600026**
OEM No. 556018769



**QTY 2 - SUPPORT
BRACKET 5600027**
OEM No. 56212345

SANDVIK TH663 / TH551 Truck

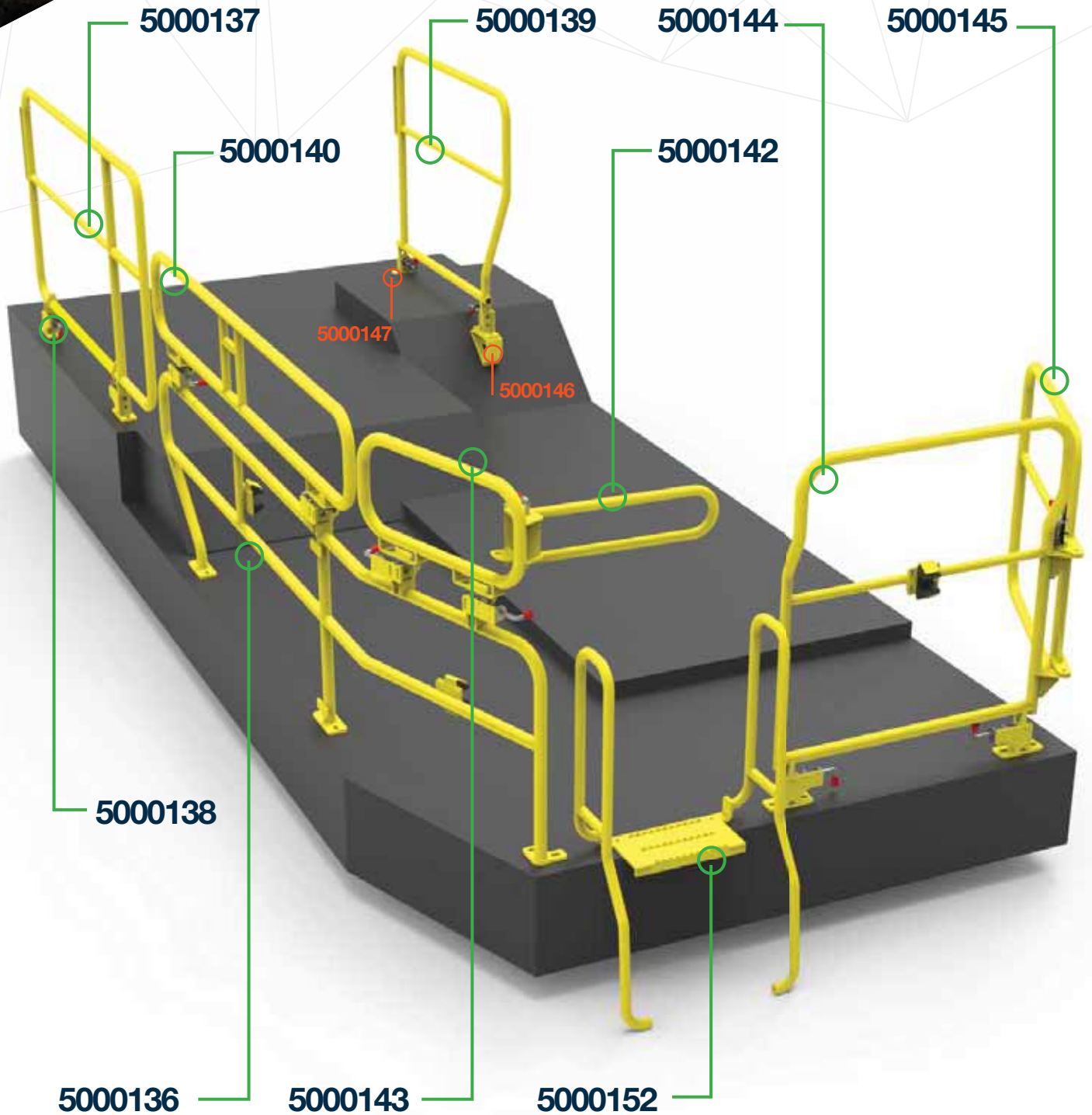

SANDVIK TH663 / TH551 TRUCK



HANDRAIL 5000136
OEM No. BG00213893



HANDRAIL 5000137
OEM No. BG00204159



HANDRAIL 5000139
OEM No. BG00204240



HANDRAIL 5000145
OEM No. BG00208760



HANDRAIL 5000144
OEM No. BG00202032



HANDRAIL 5000142
OEM No. BG00329584



HANDRAIL 5000143
OEM No. BG00202490



HANDRAIL 5000140
OEM No. BG00202252



LADDER 5000152
OEM No. BG00210677



HANDRAIL 5000138
OEM No. BG00204183



LATCH 5000149
OEM No. BG00214267 LH



SUPPORT BRACKET 5000147
OEM No. 56209439



SUPPORT BRACKET 5000146
OEM No. BG00236951



*** LADDER 5000151**
OEM No. 56210006 - Step Ladder



LATCH 5000148
OEM No. BG00214262 RH

FULL HANDRAIL SET TO SUIT SANDVIK TH663 TRUCK PART NO: 5000150

SANDVIK TH663 / TH551 Truck

SANDVIK TH663 / TH551 Front Low Folding Handrail

This new design has been created to avoid the damages that occur on handrails that do not fold flat on the deck.

Benefits include:

- ▶ Replaces the long mid folding rail on the right hand side of the truck
- ▶ New low-folding design
- ▶ Reduced damage to front handrails

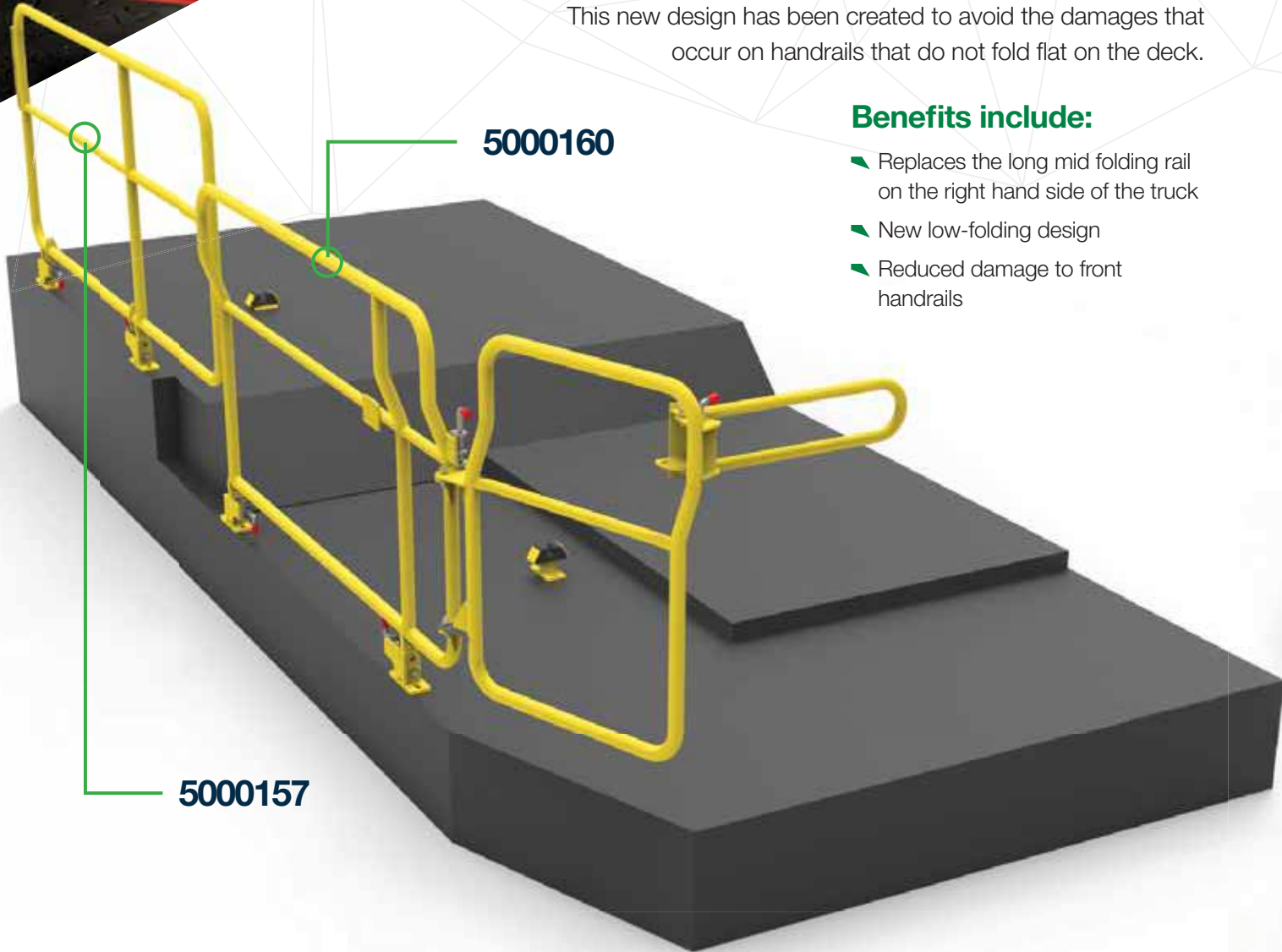

HANDRAIL 5000157



HANDRAIL 5000160

SANDVIK TH663 / TH551 Rear Tray Protection

Benefits include:

- Designed for the TH663 and TH551 trucks to prevent falls and slips off the back of the truck when the tray is up
- Permanently fixed onto the truck
- Fold in gates ensure that the handrail setup stays compact when not in use

PART NO. 5552677

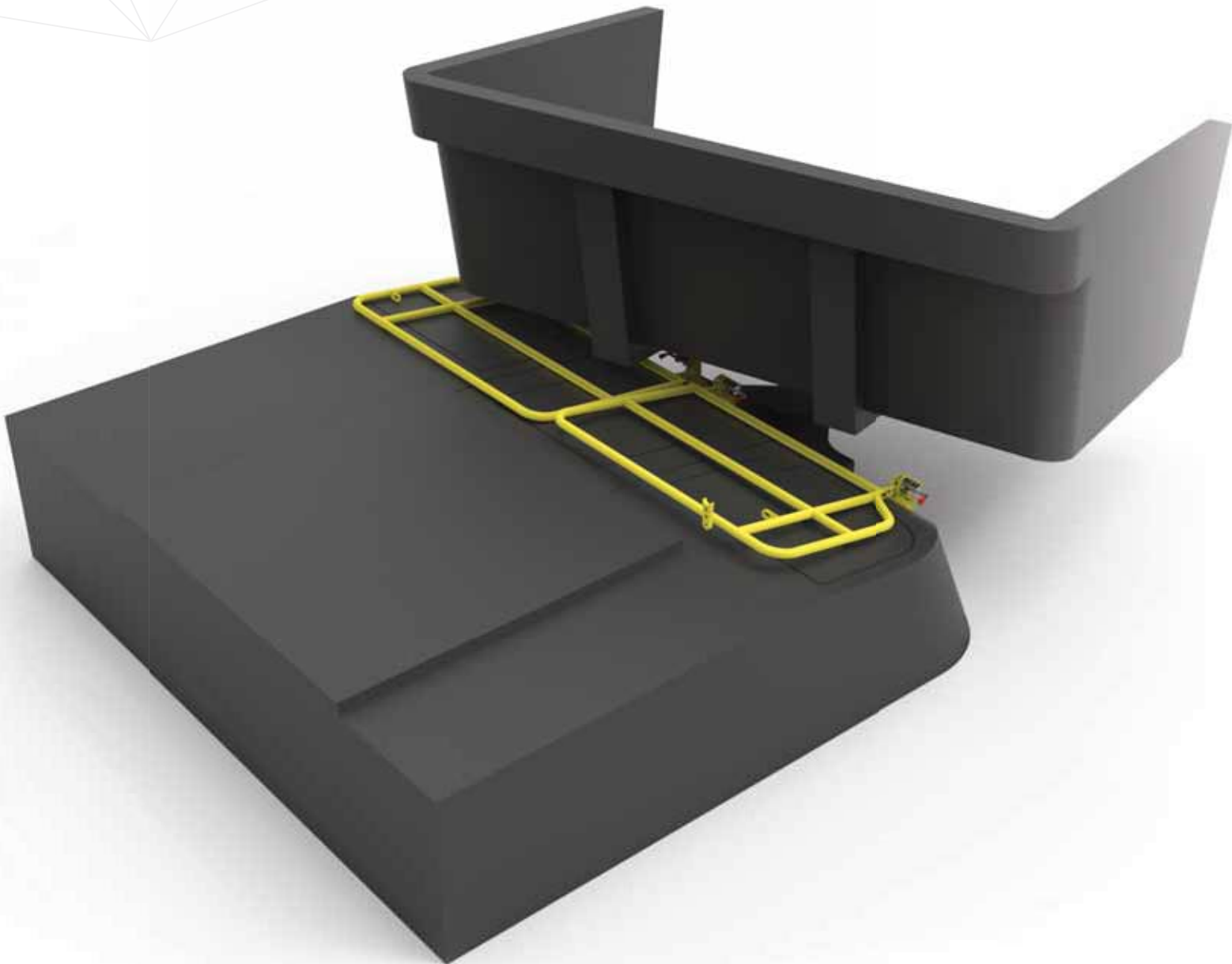

SANDVIK DD421 DRILL



SANDVIK **DD421** DRILL



HOSE GUIDE ASSEMBLY 5000039
OEM No.32821157

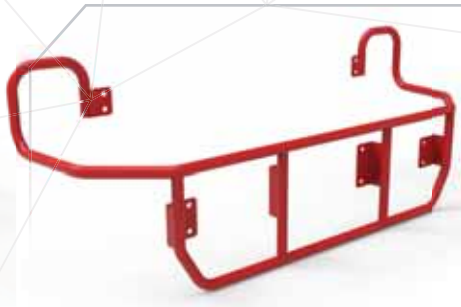

HOSE GUIDE ASSEMBLY 5000043
OEM No.35225658



HOSE GUIDE ASSEMBLY 5000042
OEM No.5239618



HOSE GUIDE ASSEMBLY 5000041
OEM No.35255508



HOSE GUIDE ASSEMBLY 5000038
OEM No.55054734



**DD421 HYDRAULIC
RAM CLAMP - 200MM**
5000174



**DD421 HYDRAULIC
RAM CLAMP - 350MM**
5600051



**DD421 HYDRAULIC
RAM CLAMP - 500MM**
5000175

Bend-tech Handrail System to suit Epiroc MT65 2017 & Beyond

Make your handrail storage and replacement more efficient, and **SAVE 62%** on your handrail costs (compared to OEM handrails)

- Reduce over ordering and wastage
- Easy part identification
- Rack galvanised and certified
- Also available for Caterpillar and Sandvik machines



Rack capacity:
3 complete sets

“**Making maintenance on-site safe, efficient and easy**”

Buy one complete set for your machine and we will supply a dedicated storage rack free of charge.

Bend-tech Handrail System to suit CAT2900

Make your handrail storage and replacement more efficient, and **SAVE 56%** on your handrail costs (compared to OEM handrails)

- Reduce over ordering and wastage
- Easy part identification
- Rack galvanised and certified
- Also available for Sandvik and Epiroc machines



Rack capacity:
3 complete sets

“**Making maintenance on-site safe, efficient and easy**”

Buy one complete set for your machine and we will supply a dedicated storage rack free of charge.

Maintenance Platforms



Part No. 5501823

CAT AD30 Tray Access Platform

Construction: Heavy duty aluminium

Forklift Slots:

- Non-slip grating
- Handrails fully removable
- Self-closing gate

WLL: 600kg

Height: 2150mm



Part No. 5501806

CAT AD45B Rear Tray Access Platform

Construction: Heavy duty aluminium

Forklift Slots:

- Non-slip grating
- Handrails fully removable
- Self-closing gate

WLL: 600kg

Height: 2550mm

CAT AD55B Access Platform

Construction: Heavy duty aluminium

Forklift Slots:

- Non-slip stairway and work area
- Self-levelling jacks
- Self-closing gate
- Foldable handrail wings

WLL: 600kg

Height: 2200mm



Part No. 5501846

Maintenance Platforms



Part No. 5501730

CAT 2900 Bucket Reconditioning Platform

Construction: Heavy duty aluminium

Forklift Slots:

- 4 x sections bolt together to combine in one square shaped platform
- Removable handrails

WLL: 250kg

Height: 1700mm

SANDVIK LH621 Loader Front Access Platform

Construction: Heavy duty aluminium

Forklift Slots:

- Platforms allow easy access from the bucket right to the cab
- Left hand and Right hand are symmetrical
- Double height handrails at tyre points to prevent falls
- Flip up grating sections on deck



Part No. 5501967



“ Engineered tough but light enough to carry ”

Alltuff Stands

Alltuff Stands have been engineered to transform safety and combat the failures associated with traditional work stands. Alltuff Stands are a high capacity light-weight stand with load ratings of 15T and 30T and a maximum manual handling weight of 14kg.

Available at three fixed heights:



15 Tonne Equipment Work Stand

- 500mm - 5001850
- 600mm - 5001851
- 750mm - 5001852



30 Tonne Equipment Work Stand

- 500mm - 5001853
- 600mm - 5001854
- 750mm - 5001855

Workshop Trestle Stands

Our trestle stands are engineered and certified with full compliance with Australian Standards. Designed for safe, efficient and easy site maintenance and available in lightweight aluminium or steel.

Features include:

- Removable top sacrificial section
- Certification plates and SWL markings
- Heavy duty steel or aluminium construction
- Stocked and available for immediate despatch

10T (SWL)
5001813
2400mm (w)
x 650mm (h)



SWL = 2T



SWL = 5T



2T (SWL)
5001747
1000mm (w)
x 900mm (h)

5T (SWL) 5001805
1000mm (w) x 900mm (h)
5T (SWL) 5001760
2400mm (w) x 900mm (h)



Aluminium

750kg (SWL) - 5501966

1500mm (w) x 900mm (h)

750kg (SWL) - 5502035

1200mm (w) x 900mm (h)



General Purpose Steel Rack

Our general-purpose steel racks are available in three standard configurations:

➤ 6m - 5000222 ➤ 7.5m - 5000221 ➤ 9m - 5000219

Features include:

- 8 shelves (4 either side)
- 3T (SWL) per shelf
- Lifting eyes for easy mobility and transport
- Modular design for ease of transport and erection on-site
- Cantilevered to provide optimum space utilisation
- Fully engineered and certified with Australian Standards
- Available in 6m, 7.5m and 9m configurations

Workshop Whiteboard Benches

Our whiteboard workbench is designed to encourage workshop efficiency and collaboration. Incorporating a large workbench, storage shelving and whiteboard provides your team with a base to work, delegate and organise.

Features include:

- Heavy duty mine specified construction
- Heavy duty castors for easy mobility
- Customisable for your specifications
- Large 1450mm whiteboard

Part No. 5001812





Our long-standing relationships, expertise and dynamic team of solutions engineers has enabled us to provide certified efficiencies across a range of fixed plant scenarios. We understand that fixed plant maintenance requires safety, speed, accuracy and reliable execution to achieve operational efficiency. This has led us to develop a range of solutions designed and engineered to satisfy these very requirements.

The ability to 3D scan, process, design, engineer and fabricate means we can solve your on-site problems. Ensuring certification and compliance is at the forefront of every product or service and understanding that some situations require customisation; we are trusted partners in safety, efficiency and productivity.



PERTH 08 9459 8600
SYDNEY 02 9764 6607
BRISBANE 07 3117 3780

KALGOORLIE 08 9021 8300
NEWMAN 08 9175 1164
MOUNT ISA 07 4743 6458

sales@bendtechgroup.com.au
www.bendtechgroup.com.au

All manufacturers names, number, symbols, photos and description are for reference purpose only and do not imply that parts listed are products of the manufacturers